

TWO-COMPONENT LINK MAPS IN MANIFOLDS

DISSERTATION zur Erlangung des Grades eines Doktors
der Naturwissenschaften

Alexander Pilz

Fachbereich Mathematik der Universität Siegen

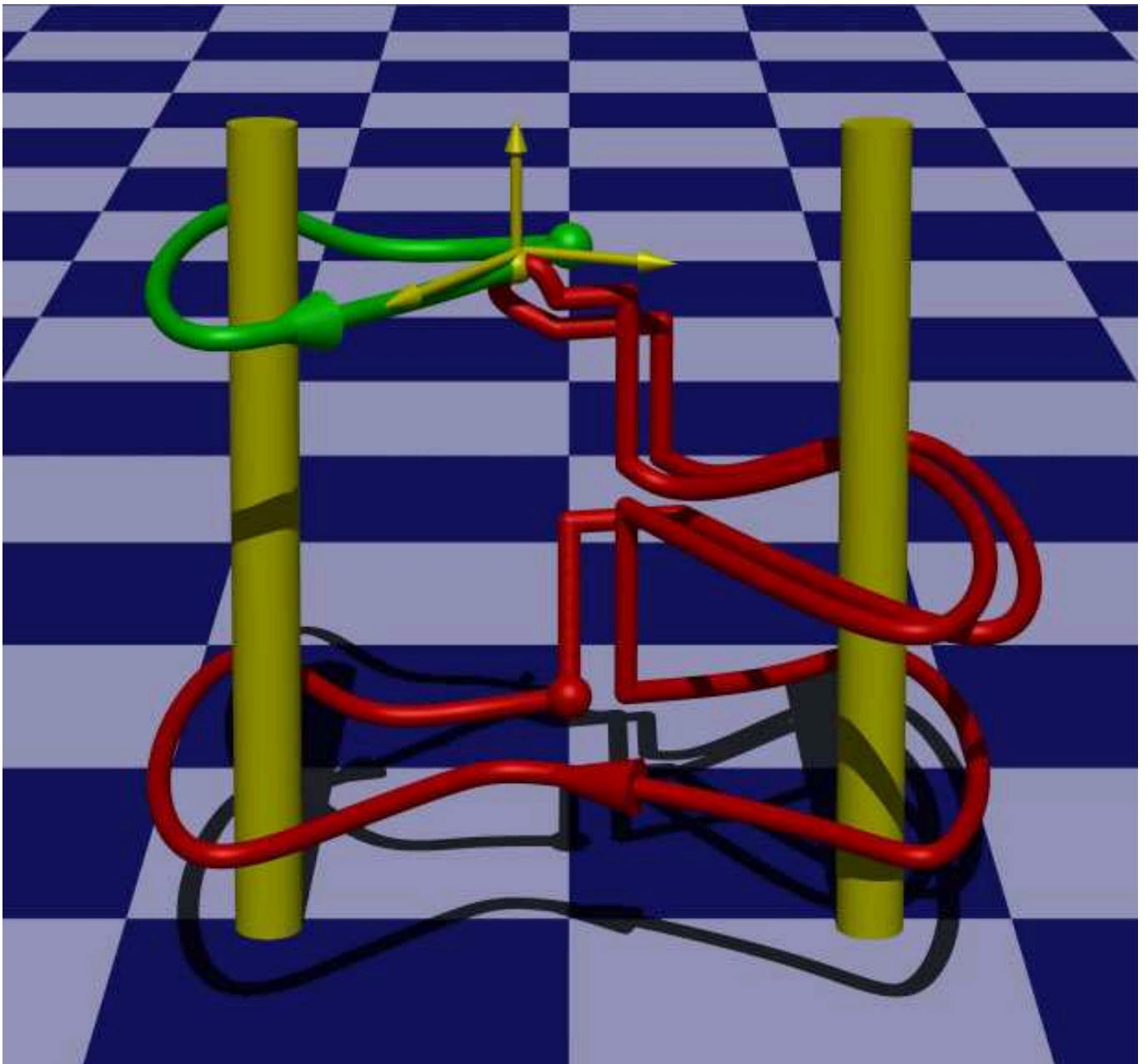

TWO-COMPONENT LINK MAPS IN MANIFOLDS

DISSERTATION

zur Erlangung des Grades eines Doktors
der Naturwissenschaften



vorgelegt von
Dipl.-Math. Alexander Pilz
aus Tangermünde

eingereicht beim Fachbereich Mathematik
der Universität Siegen

Januar 2004

Dekan: Prof. Dr. Hans-Jürgen Reinhardt

Gutachter: Prof. Dr. Ulrich Koschorke

Prof. Dr. Uwe Kaiser

Disputation: 29.01.2004

Internetpublikation der Universität Siegen : urn:nbn:de:hbz:467-936

Zusammenfassung

In den achtziger Jahren des letzten Jahrhunderts wurde die α -Invariante verwendet, um sphärische Verschlingungsabbildungen zu studieren, d.h. stetige Abbildungen zweier Sphären S^p, S^q in den euklidischen Raum \mathbb{R}^m mit disjunkten Bildern. Man beachte, dass Selbstdurchdringungen der einzelnen Komponenten durchaus erlaubt sind. Es stellte sich heraus, dass α in einem gewissen Dimensionsbereich ($2p + 2q \leq 3m - 5$) Verschlingungsabbildungen klassifiziert, d.h. bis auf Homotopie durch Verschlingungsabbildungen.

In der vorliegenden Arbeit untersuchen wir verallgemeinerte Verschlingungsabbildungen, d.h. stetige Abbildungen zweier kompakter Mannigfaltigkeiten M^m und N^n mit disjunkten Bildern in eine Zielmannigfaltigkeit vom Typ $Q^q \times \mathbb{R}$. Die durch den zweiten Faktor gegebene affine Struktur macht es uns möglich, eine α verallgemeinernde Version α_w zu definieren, die zusätzlich eine Wichtung durch gewisse Doppelnebenklassen von $\pi_1(Q)$ für jede Zusammenhangskomponente der α repräsentierenden Schnittmannigfaltigkeit vornimmt. Wir weisen nach, dass α_w invariant ist bis auf basispunkterhaltende Verschlingungshomotopie.

Weiterhin zeigt sich, dass die Invariante α_w den basispunkterhaltenden Verschlingungshomotopietyp vollständig bestimmt, wenn $1 \leq m, n$ und $m + n = q$ gilt. Für andere Dimensionsbereiche können viele durch α_w unterscheidbare Verschlingungsabbildungen angegeben werden.

Beim Übergang zu basispunktfreier Verschlingungshomotopie, welche die natürlichere Relation bzgl. Verschlingungsabbildungen zu sein scheint, verändern

sich die für die Wichtungen verwendeten Systeme von Doppelnebenklassen, so dass im Allgemeinen eine “Liftung” von α_w zu einer Invarianten bzgl. basispunktfreier Verschlingungshomotopie unmöglich ist. Allerdings treten diese Probleme nicht auf, wenn $\pi_1(M) = 1 = \pi_1(N)$ erfüllt (z.B. höherdimensionale Sphären oder geeignete Tori) oder $\pi_1(Q)$ abelsch ist. In beiden Fällen läßt sich eine Liftung $\tilde{\alpha}_w$ definieren, die im Dimensionsbereich $m + n = q$ für $m, n \geq 1$ klassifizierend ist.

Abstract

In the eighties of the last century the generalized linking number α was used to study spherical link maps in the euclidean space \mathbb{R}^m , i.e. maps of two spheres S^p, S^q with disjoint images. It turned out that in a certain dimension range ($2p + 2q \leq 3m - 5$) α classifies link maps up to link homotopy, i.e. homotopy through link maps.

In the present thesis we investigate generalized link maps, i.e. continuous maps of two compact manifolds M^m and N^n , resp., with disjoint images into a manifold of type $Q \times \mathbb{R}$. Because of the affine structure given by the second factor we are able to construct a refinement α_w of α . The refinement is based on a weighting of each path component of the intersection manifold representing α by double cosets of $\pi_1(Q)$. We prove that α_w is invariant up to base point preserving link homotopy.

Furthermore we can show that in the dimension range where $1 \leq m, n$ and $m + n = q$ holds our invariant determines the link homotopy type completely. For other dimension settings we construct many examples with different link homotopy type.

Consider now the relation of base point free link homotopy, which seems to be more natural for link maps. We are faced with the problem that a (free) link homotopy changes the target group of α_w . Thus a “lifting” of α_w to an invariant concerning base point free link homotopy fails in general. But there are no problems if $\pi_1(M) = 1 = \pi_1(N)$ (i.e. for higher dimensional spheres or appropriate tori) or abelian fundamental group of Q . In both cases we can

define a lifting $\tilde{\alpha}_w$, which classifies in the dimension range where $1 \leq m, n$ and $m + n = q$ holds.

Acknowledgments

First of all I wish to express my gratitude to my first advisor Prof. Dr. Ulrich Koschorke. Beside his advices and suggestions, which were very helpful in the clarification of many details, he offered me the position of a scientific assistant in the topology workgroup over the last years. Without his kind support a completion of this work were not possible. I would like to thank Prof. Dr. Uwe Kaiser for many interesting and encouraging talks about the topic. At all times he was up to date in new developments in link theory. That was very helpful.

I am very grateful to all the support I have received whilst researching and writing up the dissertation. Thanks especially go to PD Dr. Alexander Felshtyn, Dr. Jochen Kroll, Dr. Achill Schürmann and many other of my colleagues at the University of Siegen.

I'd also like to thank my wife Martje and my son Moritz. They have been very patient with me when no work was forthcoming.

Contents

Zusammenfassung	iii
Abstract	v
Acknowledgments	vii
List of Figures	xi
1 Introduction	1
2 Basics and background in topology	7
2.1 Manifolds and differentials	7
2.2 Pontrjagin-Thom construction	9
2.3 Stable framings and orientations	11
3 The weighted linking number α_w	15
3.1 Link maps and link homotopy	15
3.2 Definition of α_w	19
3.3 Homotopy invariance of α_w	27
3.4 Symmetry relations of α_w	40
4 The classical dimension setting	48
4.1 Proof of the classification result	52
5 Results in higher dimensions	59
5.1 Construction of link maps in standard form	59
5.2 The special case $m + n = q$	64

6 Base point free link homotopy	68
Bibliography	74

List of Figures

2.1. Collapsing map of Pontrjagin and Thom	10
3.1. Deformation h	19
3.2. Definition of $\bar{\omega}_i$ if $F_1 \times f_2$ is already transverse to Δ	21
3.3. Difference between two choices of β	21
3.4. Kervaire embedding of $S^p \times B^{q+1}$ in $S^{p+q+1} = \mathbb{R}^{p+q+1} \cup \{\infty\}$. .	25
3.5. $\bar{\omega}'_i \simeq \bar{\omega}_i \text{ rel } \{0, 1\}$	28
3.6. Types of path components of \bar{S}	30
3.7. $h' \cdot h''$, where h'' is restricted to $h'_1(I)$	32
3.8. Homotopy of $\bar{\omega}_1^1$ to $\bar{\omega}_1^0$ and $\bar{\omega}_1^1$, resp., if both H_0 and H_1 are product maps	33
3.9. a): Homotopy \bar{H} of $\bar{\omega}$ to $\bar{\omega}'$ if \bar{h} is a product map and $F_1 \times f_2 \pitchfork \Delta$, $F'_1 \times f_2 \pitchfork \Delta$; b): h' in $M \times I \times N \times I$	37
3.10. Comparison of $\alpha_w(f_1 \sqcup f_2)$ and $\bar{\alpha}_w(f_2 \sqcup f_1)$	44
3.11. Identification $I(\text{pr}_{1*}(\sigma_1), \text{pr}_{1*}(\sigma_2)) = \alpha_w(f_1 \sqcup f_2) - \bar{\alpha}_w(f_1 \sqcup f_2)$.	47
4.1. Surface F with genus g and r holes	49
4.2. Example for a computation of α_w	51
4.3. Orientation of the meridian m^1	53
4.4. Construction of canonical links with prescribed α_w -Invariant . .	54
4.5. Link homotopy of $f_1^0 \sqcup (f_2^0 \cdot m^1 \cdot m^\gamma)$ to $f_1^0 \sqcup (f_2^0 \cdot m^{\bar{\sigma}^1} \cdot m^\gamma)$. . .	56
4.6. Link homotopy of $f_1^0 \sqcup (f_2^0 \cdot m^1 \cdot m^\gamma)$ to $f_1^0 \sqcup (f_2^0 \cdot m^1 \cdot m^{\gamma \cdot \bar{\sigma}^2})$ dual to the homotopy in figure 4.5.	56
4.7. Deformation of $f = f_1 \sqcup f_2$ into standard form	57

5.1.	construction of $(g, \tau)(f^0)$	61
5.2.	Link homotopy to deform the commutator of two meridians of f_1^0 to a point	64
5.3.	finger moves along $F(\gamma_i)$	66
6.1.	Translation of weightings	70

1 Introduction

Let M^3 be a 3-dimensional manifold. A link map f is a map

$$f = f_1 \sqcup f_2 \sqcup \dots \sqcup f_r : S^1 \sqcup S^1 \sqcup \dots \sqcup S^1 \rightarrow M^3,$$

such that $f_i(S^1) \cap f_j(S^1) = \emptyset$, $i \neq j$, $1 \leq i, j \leq r$. Two link maps f, g are said to be link homotopic if there is a continuous one-parameter family of link maps F_t , such that $F_0 = f$ and $F_1 = g$. JOHN MILNOR introduced the relation of link homotopy to study linking phenomena in 3-dimensional manifolds, i.e. to ignore completely all knotting phenomena of each component, [Mil54]. But in spite of this crude relation it seems to be not easy to give a classification of link maps. MILNOR was able to give a classification for two and three component link maps in the case where $M^3 = \mathbb{R}^3$. Furthermore he gave an algorithm which tells us whether a given link map with an arbitrary number of components is trivial up to link homotopy.

Later P. SCOTT [Sco68] studied link maps $f : S^p \sqcup S^q \rightarrow S^m$, whose link homotopy classes he denoted by $LM_{p,q}^m$. He extended the classical linking number lk of a two component link in \mathbb{R}^3 to the α -invariant in higher dimensions:

$$\alpha : LM_{p,q}^m \rightarrow \pi_{p+q}(S^{m-1}),$$

which is represented by the difference map

$$\begin{aligned} \phi : S^p \times S^q &\rightarrow S^{m-1}, \\ (x, y) &\mapsto \frac{f(x) - f(y)}{\|f(x) - f(y)\|}. \end{aligned}$$

Note that if $p, q \leq m - 2$ the Puppe-sequence implies that $[S^p \times S^q, S^{m-1}] = \pi_{p+q}(S^{m-1})$. SCOTT obtained the first classification results in the dimension range $p, q \leq m - 3, p + 2q \leq 2m - 4$ using the α -invariant.

The α -invariant was the starting point to a whole series of papers by different authors: W.S. MASSEY & D. ROLFSEN [MR85], R. FENN & D. ROLFSEN [Fen86], P. KIRK [Kir90, Kir88] and U. KOSCHORKE [Kos88, Kos90, Kos92] and V. NEZHINSKIJ [Nez91]. The most general result currently available in higher dimensional link homotopy with two components is the classification exact sequence of U. KOSCHORKE established in [Kos90]. Applying this one gets the classification result of α in the 2-metastable range $2p + 2q \leq 3m - 5$ provided either $p \geq m - 2$, or $3q + 3 \leq 2m$ holds. N. HABEGGER & U. KAISER [HK98] were able to remove the last restrictions and showed that the classification range of α is exact the 2-metastable range.

In [Kos88] U. KOSCHORKE extended the definition of the α -invariant to generalized link maps:

$$f = f_1 \sqcup f_2 : M^m \sqcup N^n \rightarrow S^q,$$

where M^m and N^n are arbitrary manifolds of dimension m and n , resp., with some additional structure. He chooses a (relative) bordism F_1 for f_1 and defined $\alpha(f)$ to be the bordism class of the *coincidence manifold* $S := (F_1 \times f_2)^{-1}(\Delta)$ with additional structure, where $F_1 \times f_2 : M \times N \rightarrow S^q \times S^q$ is approximated to be transverse to the diagonal $\Delta := \{(x, x) : x \in S^q\} \subset S^q \times S^q$. It turns out that $\alpha(f)$ is invariant up to link homotopy and in fact equal to the homotopy class of the difference map ϕ provided $m, n \leq q - 2$.

But by the lack of a relative bordism of f_1 there is no general definition of α for link maps:

$$f = f_1 \sqcup f_2 : M^m \sqcup N^n \rightarrow Q^q,$$

if the target space Q^q is an arbitrary manifold.

In the present thesis we investigate the case where the target space has more structure and is of the form $Q^q \times \mathbb{R}$. Then there is a standard bordism of f_1 required in the definition of α : Pull f_1 in the positive \mathbb{R} -direction until it

is completely over f_2 according to the \mathbb{R} -factor. The coincidence manifold S consists of a finite number of path components S_i . We construct a Wall-type refinement of α which we call α_w . Here the subscript w indicates a “weighting” of each path component S_i . We will assign to each S_i a certain double coset $[\omega]$ related to an element $\omega_i \in \pi_1(Q, *)$ (compare chapter 3.2). The double cosets depend on the subgroups induced by the homotopy classes of f_1 and f_2 . Let Ω_* be one of the graded bordism rings: \mathfrak{N}_* (unoriented), Ω_*^{SO} (oriented) or Ω_*^{fr} (stably framed). Then we get the following:

Theorem 3.18. *Let M, N and Q , resp., be pointed manifolds of dimensions m, n and q , resp., representing elements in Ω_* . Furthermore let $f : M \sqcup N \rightarrow Q \times \mathbb{R}$ be a based link map. Then*

$$\alpha_w(f) := \sum [S_i][\omega_i]$$

is invariant up to base point preserving link homotopy.

A very similar construction was defined by R. SCHNEIDERMAN [Sch03] for classical links in 3-manifolds.

Define $BLM_{(\sigma_1, \sigma_2)}$ to be the set of all base point preserving link homotopy classes of based link maps $f = f_1 \sqcup f_2$ such that $\sigma_1 = [f_1] \in [(M, *_1), (Q \times \mathbb{R}, \bar{*}_1)]$ and $\sigma_2 = [f_2] \in [(N, *_2), (Q \times \mathbb{R}, \bar{*}_2)]$ where $\bar{*}_1 \neq \bar{*}_2$. Let F be an oriented surface and $f : S^1 \sqcup S^1 \rightarrow F \times I$ an oriented link map. Denote by $\Lambda_{(\bar{\sigma}_1, \bar{\sigma}_2)} = \langle [\text{pr} \circ f_1] \rangle \setminus \pi_1(F, *) / \langle [\text{pr} \circ f_2] \rangle$ the target group of α_w in this case ($\text{pr} : F \times I \rightarrow F$ is the projection onto the first factor). Using a *standard form* of two-component link maps in $F \times I$ we can use our invariant α_w to prove the following theorem:

Theorem 4.4. *If F is an oriented, compact, connected surface. Then α_w is a bijective map between the set $BLM_{(\sigma_1, \sigma_2)}$ of classes of base point preserving link maps up to base point preserving link homotopy and $\Lambda_{(\bar{\sigma}_1, \bar{\sigma}_2)}$.*

It is easy to see that the result holds if we replace oriented by unoriented link maps.

The construction of our standard form can be extended to higher dimensions, i.e. to link maps $f = f_1 \sqcup f_2 : M^m \sqcup N^n \rightarrow Q^q \times \mathbb{R}$. Roughly speaking consider $\sigma_1 \in [(M, *_1), (Q \times \mathbb{R}, \bar{*}_1)]$ and $\sigma_2 \in [(N, *_2), (Q \times \mathbb{R}, \bar{*}_2)]$, $\bar{*}_1 = (*, t_1)$, $\bar{*}_2 = (*, t_2)$ with $t_1 > t_2$. Then represent σ_i by a map $f_i^0 \subset Q \times \{t_i\}$ for $i = 1, 2$, such that both are embedded near the base point. Now perform a ‘‘finger move’’ along a prescribed loop τ in $Q \times (t_2, t_1)$ and wrap around the meridian sphere MS of a point near the image of the base point $*_1$ by a map prescribed by $g \in \pi_n(S^{q-m})$. The result is a link map $f' = f'_1 \sqcup f'_2$ with the same homotopy classes of its components and $\alpha_w(f') = [E^\infty \circ PT^{-1}(g)][\gamma]$ (the finger move is a homotopy of f_2^0 , so it does not change the homotopy class of f_2^0). Here PT denotes the collapse map in the Pontrjagin-Thom construction (compare section 2.2). This construction can be extended to a finite number of elements τ_i and g_i . This results in

Lemma 5.3. *If $1 \leq m \leq q - 1$ and $1 \leq n \leq 2(q - m) - 1$ the invariant α_w is onto. So α_w distinguishes between many (based) link homotopy classes of two-component framed link maps.*

If the dimensions of M and N are ‘‘dual’’ to each other we are able to prove the classification result:

Theorem 5.4. *Assume that $m, n \geq 1$ and $m + n = q$. Then α_w is a bijection, i.e. α_w is a full invariant of $BLM_{(\sigma_1, \sigma_2)}$.*

Up to this time we studied only base point preserving link homotopy. But base point free link homotopy seems to be the more natural relation. What happens if we want to construct an extension of α_w to base point free link homotopy? In general the problem is that we are faced with a changing of the target $\Lambda_{(\bar{\sigma}_1, \bar{\sigma}_2)}$ if we compute α_w for two different based representatives of a free link homotopy class. But it is not hard to see that there is some functorial description of this changing (compare Proposition 6.3). So we can establish a necessary condition for link maps to be link homotopic. Denote by f^b a fixed based representative of the link map f . By a basing construction along loops

which represent $(\gamma_1, \gamma_2) \in \pi_1(Q, *) \times \pi_2(Q, *)$ we can change a based link map g^b to other based representatives of g which we call $g_{(\gamma_1, \gamma_2)}^b$.

Proposition 6.4. *If $\alpha_w(f^b) \neq \alpha_w(g_{(\gamma_1, \gamma_2)}^b)$ holds for all $(\gamma_1, \gamma_2) \in \pi_1(Q, *) \times \pi_1(Q, *)$. Then maps f and g cannot be link homotopic.*

On the other side if $\pi_1(Q, *)$ is an abelian group or if the induced subgroups $f_{1\#}(\pi_1(M, *_1))$ and $f_{2\#}(\pi_1(N, *_2))$ are contained in the centralizer of $\pi_1(Q, *)$ the target $\Lambda_{(\bar{\sigma}_1, \bar{\sigma}_2)}$ of α_w does not change under a free link homotopy between based maps. That is why we can lift our invariant α_w to $\tilde{\alpha}_w$ which is invariant for based link maps up to (free) link homotopy. Applying $\tilde{\alpha}_w$ we can extend the classification results to base point free free link homotopy:

Theorem 6.6. *Let $m + n = q \geq 2$ and M, N and Q , resp., be stably framed manifolds of dimension $m, n \geq 1$ and q , resp. Furthermore assume that $\pi_1(Q, *)$ is abelian or $\pi_1(M, *_1) = 1 = \pi_1(N, *_2)$. Then the invariant $\tilde{\alpha}_w$ is a bijection between $LM_{M,N}^Q$ and $\Omega_{n+m-q}^{fr}[\Lambda_{(\bar{\sigma}_1, \bar{\sigma}_2)}] / \sim$. The same is true in the case of two oriented circles in $F \times I$, where F denotes an oriented surface with abelian fundamental group.*

This result is an extension of results of U. DAHLMIEIER [Dah94] and in some sense of U. KOSCHORKE [Kos03a].

We want to conclude this introduction with some remarks on future developments based on the construction of α_w . To get a better understanding of what α_w is really measuring we can try to give a certain over-crossing interpretation of α_w with relations to new results of U. KOSCHORKE [Kos03b] in Nielsen coincidence theory. His new approaches seem to be very fruitful in many directions.

The thesis is organized as follows. In chapter 2 we recapitulate some basic facts and notations from differential topology to the convenience of the reader. The invariant α_w for based link maps will be constructed in chapter 3, where we also prove the invariance of α_w up to based point preserving link homotopy and establish some symmetry relations. In chapter 4 we discuss link maps in classical

dimensions and give a proof of the classification theorem for $BLM_{(\sigma_1, \sigma_2)}$. The construction used in this proof will be extended in chapter 5 to give many examples of link homotopy classes in higher dimensions. The proof of Theorem 5.4 can be found in section 5.4. In the concluding chapter 6 we study the relation to base point free link homotopy and prove Proposition 6.4 and Theorem 6.6.

2 Basics and background in differential topology

In the first chapter we want to give a short overview about some basics of differential topology. We describe some well-known constructions and facts which we will use frequently.

2.1 Manifolds and differentials

M^m will always denote a C^∞ -differentiable (smooth) manifold of dimension m . If $f : M \rightarrow M'$ is a C^∞ -differentiable (smooth) map, then $Tf : TM \rightarrow TM'$ stands for the induced map on the tangential bundles, i.e. $Tf(x, v) = (f(x), df_x(v))$ for $x \in M$ and $v \in T_x(M)$, where $df_x : T_x M \rightarrow T_{f(x)} M'$ denotes the differential of f in x .

Let M^m be an orientable (smooth) manifold. Then an orientation of M^m corresponds to an orientation of the tangent bundle of M^m , i.e. for every point $x \in M$ there is a neighborhood $x \in U$ and a m -tuple s_1, \dots, s_m of sections in $TM|_U$, so that the ordered set $[s_1(y), \dots, s_m(y)]$ determines an orientation of $T_y M$ for each $y \in U$. If we now consider a product manifold $P = M \times N$ of oriented manifolds we will equip P with the following canonical orientation induced by M and N : Assume that the ordered basis $v_1, \dots, v_m \in T_x M$ represents the local orientation in x and the ordered basis $w_1, \dots, w_n \in T_y N$ represents the local orientation in y . Then the $n + m$ -tuple $(v_1, \dots, v_m, w_1, \dots, w_n)$ determines a local orientation of $T_{(x,y)}(M \times N)$. It is easy to see that these local orientations induce an orientation of P . The unit interval $I = [0, 1]$ will always be given the

orientation which is determined by a nonzero vector in positive direction.

In later chapters we will often make use of the orientation convention for the boundary ∂M of an oriented manifold M described in [MS74]: Let v_1, \dots, v_m be an oriented basis of $T_x M$ for $x \in \partial M \subset M$ such that v_1 points “outwards” of M and $v_2, \dots, v_m \in T_x(\partial M)$. The ordered basis v_2, \dots, v_m now determines the required orientation of $T_x(\partial M)$. This orientation of ∂M will be called “induced” by the orientation of M .

Lemma and Definition 2.1. Two m -dimensional manifolds M_1, M_2 will be called *bordant* if there is a $m+1$ -dimensional manifold W with $\partial W = M_1 \cup M_2$. If M_1 and M_2 are oriented, then M_1 and M_2 are said to be *oriented bordant* if ∂W with its induced orientation is orientation preserving diffeomorphic to $M_1 \sqcup -M_2$. This relation is obviously an equivalence relation (compare e.g. [MS74], §17). The *bordism classes* of (unoriented) m -dimensional manifolds will be denoted by \mathfrak{N}_m whereas oriented bordism classes of dimension m are usually denoted by Ω_m^{SO} (compare [Sto58]).

To illustrate the geometry of framed bordism structures we will first describe bordism theory in a very restrictive nature - for submanifolds of a given manifold N^n .

Lemma and Definition 2.2. Consider all triples $[i, M, F]$, where $i : M \hookrightarrow N$ is an embedding and F is a framing of the normal bundle of i , i.e. a homotopy class of a $n-m$ tuple (v_1, \dots, v_{n-m}) of linear independent sections of $\nu(i : M \hookrightarrow N)$. Then $i(M)$ is said to be a *framed submanifold* of N . Two framed submanifolds M_1, M_2 of N will be called *framed bordant* if the subset $M_1 \times [0, \varepsilon] \cup M_2 \times [1 - \varepsilon, 1]$ can be extended to a framed submanifold W of $N \times I$, such that $\partial W = M_1 \times \{0\} \cup M_2 \times \{1\} = W \cap (N \times \{0\} \cup N \times \{1\})$ and W satisfies the following framing condition: If $(v_1^i, \dots, v_{n-m}^i)$ are the framings of M_i and (w_1, \dots, w_{n-m}) is the framing of W , then we have $w_j(x, t) = (v_j^1(x), 0)$ for $t \in [0, \varepsilon]$ and $w_j(x, t) = (v_j^2(x), 0)$ for $t \in [1 - \varepsilon, 1]$. We refer to ${}^e\Omega_m^{fr}(N)$ as the set of all framed bordism classes of triples $[i, M, F]$. Again it is not hard to prove that this relation is an equivalence relation.

If there is given an embedding $j : N \hookrightarrow N'$ then j induces a map $j_* : {}^e\Omega_m^{fr}(N) \rightarrow {}^e\Omega_m^{fr}(N')$ by $j[i, M, F] = [j \circ i, M, Tj(F)]$. If there is no confusion we abbreviate $[i, M, F]$ by $[M, F]$ or even $[M]$.

Consider now an oriented manifold M without boundary. Equip $M \times I$ with the product orientation induced by M and I . So we get the trivial oriented bordism with $M \times \{1\} = -M$ and $M \times \{0\} = M$ if the dimension of m is odd, and reversed if m is even (where $=$ means diffeomorphic by an orientation preserving diffeomorphism). This can easily be seen, e.g. rotate the first vector v_1 to e (in the plane spanned by v_1 and e), where e represents the canonical orientation of I and v_1, \dots, v_m is an oriented basis of $T_x M$ in the case of $x \in M \times \{1\}$.

According to our orientation convention we use the following convention of framing the boundary of a manifold M with $\partial M \neq \emptyset$. Let $M \hookrightarrow N$ be an embedding framed by (v_1, \dots, v_{n-m}) . Then a framing of ∂M can be obtained by (n, v_1, \dots, v_{n-m}) , where n is the “outward pointing” normal vector of $\partial M \subset M$. This convention is useful because for $x \in M$ the tangent space $T_x N$ will be oriented by an oriented basis of $T_x M$ followed by a framing in x . If $x \in \partial M$ then an oriented basis of $T_x(\partial M)$, where ∂M carries the induced orientation, followed by the induced framing of ∂M gives the same orientation of $T_x N$ as above.

2.2 Pontrjagin-Thom construction

In what follows we will often make use of the *Pontrjagin-Thom construction*, a key tool to connect differential topology and homotopy theory, developed by Pontrjagin [Pon38, Pon59] and Thom [Tho54] in the 1950's. Pontrjagin introduced framed bordism to study homotopy classes of spheres. But it has turned out to be easier to enumerate homotopy classes by quite different, more algebraic methods. So the solutions in homotopy theory lead to interesting consequences in manifold theory.

We give a brief description: Let $f : N^n \rightarrow S^{n-m}$ represent an element of $[N^n, S^{n-m}]$. Approximate f by a smooth map with regular value $0 \in S^{n-m} =$

$\mathbb{R}^{n-m} \cup \{\infty\}$. Then $M = f^{-1}(0)$ is a m -dimensional submanifold of N . A canonical framing of M is given by the restriction of Tf to $TN|_M$. This map factors through TM and gives a fiberwise isomorphism of vector bundles:

$$\begin{array}{ccc} \nu(M \hookrightarrow N) & \xrightarrow{df} & \nu(0 \hookrightarrow S^{n-m}) \\ \downarrow & & \downarrow \\ M & \xrightarrow{f} & 0. \end{array}$$

Here we use the canonical framing of $0 \in S^{n-m} = \mathbb{R}^{n-m} \cup \{\infty\}$ by (e_1, \dots, e_{n-m}) . On the other hand there is a *collapse map* $PT : N \rightarrow S^{n-m}$ defined by $\nu(M \hookrightarrow$

Figure 2.1. Collapsing map of Pontrjagin and Thom

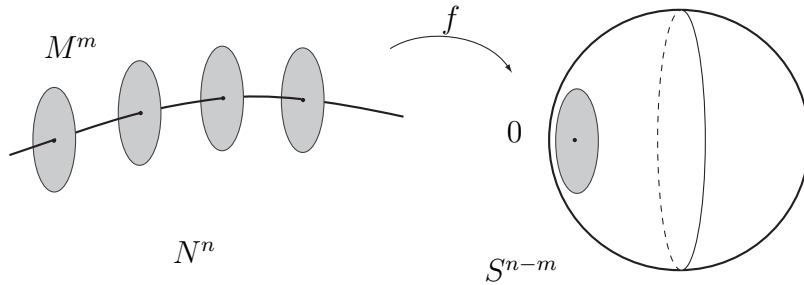

$N) \ni (p, v) \mapsto v \in \mathbb{R}^{n-m} \cup \{\infty\} = S^{n-m}$ (see figure 2.1.) and PT is constant ∞ outside a tubular neighborhood (identified with $\nu(M \hookrightarrow N)$) of M . Now Pontrjagin proved that both constructions are inverse to each other:

Theorem 2.3 (Pontrjagin). *The collapse map induces a bijection*

$$PT : e\Omega_m^{fr}(N) \longleftrightarrow [N, S^{n-m}].$$

For a proof see [Mil65] or [DK01]. ■

Remark 2.4. If we replace N by the (canonically framed) sphere of dimension n we get on the right side the n -th homotopy group of S^{n-m} . Since $\pi_n(S^{n-m})$ is an abelian group $e\Omega_m^{fr}(S^n)$ inherits an abelian group structure. This is given by disjoint union :

$$[M_1] + [M_2] := M_1 \sqcup M_2 \subset S^n \# S^n.$$

To see this we have to remember the group structure of $\pi_n(S^{n-m})$. Let $*$ be the point ∞ in all Spheres. Represent two elements $\alpha, \beta \in \pi_n(S^{n-m})$ by maps $f_1, f_2 : (S^n, *) \rightarrow (S^{n-m}, *)$ and let $\nu : (S^n, *) \rightarrow (S^n, *) \vee (S^n, *)$ be a comultiplication on S^n . Then the composition

$$(S^n, *) \xrightarrow{\nu} (S^n, *) \vee (S^n, *) \xrightarrow{(f_1, f_2)} (S^{n-m}, *)$$

leads to a well-defined element $\alpha + \beta := [(f_1, f_2) \circ \nu] \in \pi_n(S^{n-m})$ (compare [SZ94], 16.3.14). Under PT^{-1} this is exactly $M_1 \sqcup M_2 \subset S^n \# S^n$ (connected sum along the equator). Now let $d : S^n \rightarrow S^n$ be a map of $\deg(d) = -1$. Then we have $(f_1, f_1 \circ d) \circ \nu \simeq c$ by the definition of a comultiplication, where c is the constant map $S^n \rightarrow * \in S^{n-m}$. We deduce with $M_1 := f_1^{-1}(0)$ and $M_2 := (f_1 \circ d)^{-1}(0)$ that $[M_1] + [M_2] = 0$. It follows $-[M_1] = [M_2]$. But $M_2 = -M_1$, because $d|_{M_1}$ defines an orientation reversing diffeomorphism. Therefore we proved that $-[M_1] = [-M_1]$. \blacksquare

So we can produce an inverse of a bordism class $[M]$ by changing the orientation of M , or equivalently the orientation of the framing, e.g. by reflecting the first section in the framing.

2.3 Generalization to stable framings and orientations

To remove the restriction to normally framed manifolds as submanifolds of other manifolds we need to remove the reference to the embedding into a sphere. This can be done by the concept of stable (tangential) framings:

Definition 2.5. A *stable tangential* framing of a m -dimensional manifold M is an equivalence class of trivializations of $TM \oplus \varepsilon^k$ where ε^k is the trivial bundle $M \times \mathbb{R}^k$. Two trivializations

$$\varphi_1 : TM \oplus \varepsilon^{k_1} \cong \varepsilon^{m+k_1} \quad \varphi_2 : TM \oplus \varepsilon^{k_2} \cong \varepsilon^{m+k_2}$$

are considered to be equivalent if there exists some $K \gg 0$ large such that the direct sum trivializations $\varphi_1 \oplus \text{Id}_{\varepsilon^{K-k_1}}$ and $\varphi_2 \oplus \text{Id}_{\varepsilon^{K-k_2}}$ are homotopic.

Remark 2.6. A very similar definition can be given for a *stable normal framing* as equivalence class of trivializations of the normal bundle of an embedding of M into a sphere of large dimension.

For all embeddings of M^m into S^n we have the canonical splitting

$$TS^n|_M \cong TM \oplus \nu(M \hookrightarrow S^n).$$

Furthermore we know that all manifolds can be embedded into a sphere of large dimension (again $2m$ or $2m-1$ are enough: compare e.g. [Ada93] or the original papers by WHITNEY [Whi44] and HAEFLIGER/HIRSCH [HH63]). We put these facts together to obtain:

Theorem 2.7 (8.13, [DK01]). *There is a one-to-one correspondence between stable tangential framings and stable normal framings of a manifold M . More precisely:*

- (1) *Let $i : M \hookrightarrow S^k$ be an embedding. Then stable framing of TM determines a stable framing of $\nu(i)$ and conversely.*
- (2) *Let $i_j : M \hookrightarrow S^{k_j}$ be embeddings for $j = 1, 2$. For $K \gg 0$ large there exists a canonical identification (up to homotopy)*

$$\nu(i_1) \oplus \varepsilon^{K-k_1} \cong \nu(i_2) \oplus \varepsilon^{K-k_2}.$$

This means that a stable framing of $\nu(i_1)$ determines a framing of $\nu(i_2)$ and vice versa.

The *suspension* for a pointed topological space $(X, *)$ is defined by

$$SX = X \times I / \sim,$$

where \sim collapses $* \times I \cup (X \times \{0, 1\})$ to a point. Remember the fact that $SS^n = S^{n+1}$. The suspension is not only defined for topological spaces, but also for maps $f : (X, *) \rightarrow (Y, *)$. If we factor $f \times \text{Id} : X \times I \rightarrow Y \times I$ through the obvious subspaces we obtain the suspension

$$Sf : [X, Y] \rightarrow [SX, SY].$$

This yields an operator on \mathcal{TOP}_0 . In the case where X is the n -dimensional sphere, we get the suspension homomorphism $E : \pi_n(Y) \rightarrow \pi_{n+1}(SY)$. This leads to the following theorem which is the starting point for the investigation of stabilization in homotopy theory:

Theorem 2.8 (Freudenthal suspension theorem). *Suppose that Y is an $(n - 1)$ -connected space ($n \geq 2$). Then the suspension homomorphism*

$$E : \pi_k(Y) \rightarrow \pi_{k+1}(SY)$$

is an isomorphism if $k < 2n - 1$ and an epimorphism if $k = 2n - 1$.

A proof of can be found e.g. in the book of G. W. Whitehead [Whi78], chapter VII, section 7. ■

Remark 2.9. In the case where $Y = S^n$ the result can be extended to $n = 1$:

$$\pi_1(S^1) \cong \pi_2(S^2).$$

Let us consider the canonical embedding of S^n as equator of $S^{n+1} = SS^n$. The normal bundle $\nu(S^n \subset S^{n+1})$ has a canonical trivial framing induced by the framing of $\mathbb{R}^n \subset \mathbb{R}^{n+1}$, where we choose e^{n+1} as the framing vector in each point. If we have a smooth map $f : S^k \rightarrow S^n$ then the suspension Ef is smooth away from the base point ($S^n = \mathbb{R}^n \cup \{\infty\}$ with base point ∞). Clearly, the manifold $M := f^{-1}(0) = Ef^{-1}(0) \subset S^k \subset S^{k+1}$ has a canonical splitting of the normal bundle: $\nu(M \subset S^{n+1}) \cong \nu(M \subset S^n) \oplus \varepsilon$. Thus a framing of $M \subset S^n$ together with the canonical framing of $S^n \subset S^{n+1}$ yields a framing of $M \subset S^{n+1}$.

This establishes a correspondence between the suspension operation and the stabilization of a normal (or tangential) framing:

Theorem 2.10 (Pontrjagin, [Pon59]). *The stable k -stem π_k^S is isomorphic to the abelian group Ω_k^{fr} of bordism classes of stable tangentially framed k -dimensional smooth, oriented compact manifolds without boundary.*

Remark 2.11. The theorem was generalized by THOM [Tho54] to the case of other bordism structures. This is based on the following idea: The classifying bundle for trivial m -dimensional bundles is the trivial bundle ε^m over a point $\{*\}$. The *Thom space* of a bundle ξ over a compact base space is the one-point-compactification of the total space of ξ . So collapse map PT constructed above is nothing else but the *Gauß map* of $\nu(M \hookrightarrow S^n)$ extended to all of S^n to the Thom space of the total space of the classifying bundle: All points outside a tubular neighborhood of $M \hookrightarrow S^n$ will be mapped to the extra point of the compactification of $\mathbb{R}^{n-m} \cup \{\infty\} = S^{n-m}$. To add this extra point was a stroke of genius of René Thom. $BSO(k)$ and $BO(k)$, resp., are the classifying spaces for oriented and unoriented k -plane bundles. We denote the Thom spaces of the universal bundles over this spaces by $MSO(k)$ and $MO(k)$, resp. This leads to a generalization of 2.10 to oriented and unoriented bordism groups.

Theorem 2.12 (Thom, [Tho54]). *For $k > n+1$ the collapse map PT defines an isomorphism of groups:*

$$\Omega_n^{SO} \cong \pi_{n+k}(MSO(k)) \quad \mathfrak{N}_n \cong \pi_{n+k}(MO(k)),$$

where Ω_n^{SO} and \mathfrak{N}_n are the oriented and unoriented, resp., bordism classes of dimension n .

A very beautiful and compact discussion of the Pontrjagin-Thom construction can be found in the books of Milnor [Mil65], [MS74], and Davis / Kirk [DK01].

3 The weighted linking number α_w

In this chapter we construct α_w and prove the invariance of α_w under base point preserving link homotopy. Some symmetry relations of α_w will be discussed in the last section. If not stated otherwise throughout this work we will concentrate on the dimension range: $1 \leq m, n \leq q - 1$, i.e. on link maps with codimension at least two.

3.1 Link maps and link homotopy

Let M, N and P, Q be closed, connected manifolds representing elements of Ω_* of dimension m, n, p, q (Ω_* stands for one of the bordism rings $\Omega_*^{fr}, \Omega_*^{SO}$ or \mathfrak{N}_*). Pick base points $*_1 \in M, *_2 \in N$ and $\bar{*}_1 \neq \bar{*}_2 \in Q \times \mathbb{R}$.

Definition 3.1. A map $f = f_1 \sqcup f_2 : M \sqcup N \rightarrow P$ is called a *link map* if the two manifolds M and N have disjoint images, i.e. $f_1(M) \cap f_2(N) = \emptyset$.

We write

$$\mathcal{BLM}_{N,M}^Q := \{f_1 \sqcup f_2 : M \sqcup N \rightarrow Q \times \mathbb{R} \mid f \text{ a link map, } f_i(*_i) = \bar{*}_i, i = 1, 2\}$$

for the set of all *based link maps* of M and N in $Q \times \mathbb{R}$ and

$$\mathcal{LM}_{N,M}^Q := \{f_1 \sqcup f_2 : M \sqcup N \rightarrow Q \times \mathbb{R} \mid f \text{ a link map}\}$$

for the set of all link maps of M and N in $Q \times \mathbb{R}$.

Definition 3.2. Two link maps $f, g \in \mathcal{BLM}_{M,N}^Q$ are *link homotopic up to base point preserving link homotopy* if there is a (continuous) map

$$F : (M \sqcup N) \times I \rightarrow Q \times \mathbb{R},$$

such that $F_t := F|(M \sqcup N) \times \{t\}$ is a based link map. The *base point free version of link homotopy* is given by a map as before, but F_t is not assumed to be base point preserving. (Based) link homotopy is obviously an equivalence relation. The equivalence classes will be denoted by

$$BLM_{M,N}^Q \quad \text{and} \quad LM_{M,N}^Q.$$

Remark 3.3. There is an obvious map $\text{forget} : BLM_{M,N}^Q \rightarrow LM_{M,N}^Q$ which forgets the base points. The role of base points will be studied in more detail in chapter 6.

Remark 3.4. Embed $Q \times \mathbb{R}$ into an \mathbb{R}^k (e.g. $k \geq 2q + 2$ is sufficient; compare [Whi44]), the Riemannian metric induced by this embedding induces a topology on the space of all maps $g : M \sqcup N \rightarrow Q \times \mathbb{R}$, the compact open topology. In this topology we can always approximate our link maps by smooth maps (compare [Hir76]).

Remark and Definition 3.5. Let $f : (M, *_1) \rightarrow (N, *_2)$ be a map. In most cases of our constructions we want to approximate f by a smooth map h which is transverse to an (embedded) submanifold $A \subset N \setminus \{*_2\}$. Furthermore we want h to be base point preserving, i.e. $h(*_1) = *_2$. This can be done by the following construction: First consider a neighborhood U of $*_1$ and a diffeomorphism $h : (U, *_1) \rightarrow (\mathbb{R}^m, 0)$. Then define $V := h^{-1}(B_1(0))$, where $B_1(0)$ is the open ball of radius 1 around 0. Now let $\lambda : \mathbb{R}^m \rightarrow \mathbb{R}$ be a smooth function which is 1 on $B_1(0)$ and 0 for $x \in \mathbb{R}^m \setminus B_2(0)$ (compare e.g. section 2, chapter 2 in [Hir76], these functions are used to construct partitions of unity). We construct

a deformation $d : \mathbb{R}^m \times I \rightarrow \mathbb{R}^m$ by

$$d(x) := \begin{cases} (1-t)x & \|x\| < 1, \\ x - \lambda(x) \frac{tx}{\|x\|} & \|x\| \geq 1. \end{cases}$$

The homotopy $\bar{H}_t := h^{-1} \circ d_t \circ h : U \rightarrow U$ is the identity outside of $h^{-1}(B_2(0))$ and deforms $h^{-1}(B_1(0))$ to $*_1$. Extend \bar{H} to all of M by the identity to get a deformation H of M with $H_1(V) = *_1$. Then $f \circ H$ is a homotopy from f to a map $f' := f \circ H_1$ with $f'(V) = *_2$. Therefore $f'|V$ is smooth and transverse to A because $f(*_1) \cap A = \emptyset$. Now make f' transverse to A . This can be done without changing f' in a neighborhood of $*_1$ (compare e.g. [GG80], Corollary 4.12). Such a base point preserving approximation will be called *b-approximation* of f .

We need one more technical detail about transverse approximations: We want to restrict ourself to such approximations f' that will be homotopic to f in N such that the base point left fixed.

Lemma and Definition 3.6. Let $f : (M, *_1) \rightarrow (Q, *_2)$ be a map. Then there is a *b-approximation* f' of f , such that f' is transverse to an (embedded) submanifold $A \subset Q \setminus \{*_2\}$ and *b-homotopic* to f . A map f' is *b-homotopic* to f if there is a homotopy $H : M \times I \rightarrow Q$ such that $H_0(x) = f(x)$, $H_1(x) = f'(x)$ and $H_t(*_1) = *_2$. The map f' will be called a *bh-approximation* of f .

PROOF. To prove this, embed Q into an \mathbb{R}^k by i (compare Remark 3.4) and let $N(Q) \subset \mathbb{R}^k$ be a tubular neighborhood of Q . So we have a retraction $r : N(Q) \rightarrow Q$. Now take a *b-approximation* f' (transverse to A) of f such that all straight lines connecting $f(x)$ to $f'(x)$ are contained in $N(Q)$. Then we define

$$\begin{aligned} H : M \times I &\rightarrow \mathbb{R}^k, \\ (x, t) &\mapsto tf(x) + (1-t)f'(x). \end{aligned}$$

Now $r \circ H$ is a required homotopy of f to f' .

Definition 3.7. A link map f will be called *trivial* up to (based) link homotopy if there exists a link homotopy of f to a constant map const which maps M and N to $\bar{*}_1$ and $\bar{*}_2$, respectively. In the base point free case the choice of $\bar{*}_1$ and $\bar{*}_2$ gives no restriction in our setting because Q is connected and we can find (non intersecting) paths to any other choice of base points ($\dim Q = q \geq 2$).

In the next Lemma we show that our based link homotopy classes do not depend on the special choice of our base points $\bar{*}_1, \bar{*}_2 \in Q$.

Lemma 3.8. *Let $\bar{*}'_1, \bar{*}'_2$ be any other choice pair of distinct base points in Q . If $BLM_{N,M}^Q(\bar{*}_1, \bar{*}_2)$ denotes the base point preserving link homotopy classes with $f_1(*) = \bar{*}_1$ and $f_2(*) = \bar{*}_2$. Then we get a bijection:*

$$BLM_{M,N}^Q(\bar{*}_1, \bar{*}_2) \longleftrightarrow BLM_{M,N}^Q(\bar{*}'_1, \bar{*}'_2).$$

PROOF. Let $X := \{\bar{*}_1, \bar{*}_2, \bar{*}'_1, \bar{*}'_2\}$. If two points of X are equal we can show the bijection of both $BLM_{M,N}^Q(\bar{*}_1, \bar{*}_2)$ and $BLM_{M,N}^Q(\bar{*}'_1, \bar{*}'_2)$ to the link classes related to a third pair different from the set above.

So let us assume that $\#X = 4$. Choose $z \in BLM_{M,N}^Q(\bar{*}_1, \bar{*}_2)$ and $f \in z$. Because Q was assumed to be connected there is a path γ from $\bar{*}_1$ to $\bar{*}'_1$. A small tubular neighborhood of γ is diffeomorphic to D^{q+1} by a map d with $d(\bar{*}_1) = (0, \dots, 0, -1/2)$ and $d(\bar{*}'_1) = (0, \dots, 0, 1/2)$. Consider the homeomorphism h of D^{q+1} which changes only the $q+1$ -th component as shown in figure 3.1. ($h(0, \dots, 0, -1/2) = (0, \dots, 0, 1/2)$) which is the identity on the boundary of D^{q+1} . The composition $h' = d^{-1} \circ h \circ d$ (d identifies the tubular neighborhood of γ with D^{q+1}) can be extended by the identity to a homeomorphism of Q . But $f' := h' \circ f$ represents an element $z' \in BLM_{M,N}^Q(\bar{*}'_1, \bar{*}'_2)$. The map $h' : [f] \mapsto [h' \circ f]$ is a well-defined map. For let $g \in z$ and H be a link homotopy connecting f and g , then the Homotopy $h' \circ H$ connects f' and g' . h' is clearly bijective. An inverse to h' is given by a composition with h'^{-1} . In the same way we have a bijection changing $\bar{*}_2$ to $\bar{*}'_2$. ■

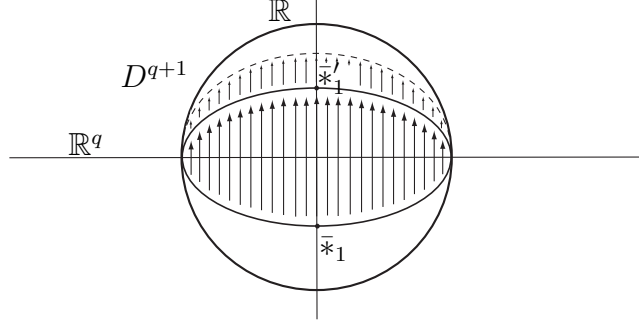
Figure 3.1. Deformation h 

Because of Lemma 3.8 we are free to choose the base points $\bar{*}_1, \bar{*}_2$ to suit our needs. We will make use of this frequently in the next chapters and we will write often $BLM_{M,N}^Q$ for $BLM_{M,N}^Q(\bar{*}_1, \bar{*}_2)$.

3.2 Definition of α_w

Let Ω_* be one of the graded bordism rings Ω_*^{fr} (stably framed), Ω_*^{SO} (oriented) or \mathfrak{N}_* (unoriented). More over let M, N and Q be closed manifolds representing elements of Ω_* of dimension m, n and q . Pick base points $*_1 \in M, *_2 \in N$ and $* \in Q$. In the following we will discuss homotopy classes of based link maps mapping the base points of M and N to $\bar{*}_1 := (*, 1), \bar{*}_2 := (*, -1) \in Q \times \mathbb{R}$, resp. Because of lemma 3.8 this is no restriction. Furthermore let $(*, 0)$ be a base point of $Q \times \mathbb{R}$. A first partition of the set $BLM_{M,N}^Q$ is given by the homotopy classes of $f_1 : (M, *_1) \rightarrow (Q \times \mathbb{R}, \bar{*}_1)$ and $f_2 : (N, *_2) \rightarrow (Q \times \mathbb{R}, \bar{*}_2)$. Let us write $BLM_{(\sigma_1, \sigma_2)}$ for all link homotopy classes of based link maps $f = f_1 \sqcup f_2$ with $[f_1] = \sigma_1$ and $[f_2] = \sigma_2$. Thus we have:

$$BLM_{M,N}^Q = \dot{\bigcup}_{(\sigma_1, \sigma_2) \in G_1 \times G_2} BLM_{(\sigma_1, \sigma_2)},$$

where $G_1 := [(M, *_1), (Q \times \mathbb{R}, \bar{*}_1)]$ and $G_2 := [(N, *_2), (Q \times \mathbb{R}, \bar{*}_2)]$.

Now consider a representative $f = f_1 \sqcup f_2$ with $[f] \in BLM_{(\sigma_1, \sigma_2)}$ as aforementioned. Let $F_1 : M \times I \rightarrow Q \times \mathbb{R}$ be a homotopy, where $F_1(x, 0) = f_1(x)$ and

$\text{pr}'_2 \circ F_1(M \times \{1\}) \subset \mathbb{R}_{>f_2} :=] \max\{(\text{pr}'_2 \circ f_2)(x) \mid x \in N\}, \infty[$. Here $\text{pr}'_2 : Q \times \mathbb{R} \rightarrow \mathbb{R}$ denotes the projection to the second factor. The diagonal Δ of $(Q \times \mathbb{R})^2$, defined as the set $\{(x, x) \mid x \in (Q \times \mathbb{R})\}$, is an $q+1$ -dimensional submanifold of $(Q \times \mathbb{R})^2$ diffeomorphic to $Q \times \mathbb{R}$. Choose a smooth bh-approximation F of the product map $F_1 \times f_2 : (M \times I) \times N \rightarrow (Q \times \mathbb{R}) \times (Q \times \mathbb{R})$, which is transverse to the diagonal Δ . Such a map always exists (remark 3.5 and lemma 3.6; note that we cannot assume F to be a product of two maps!). The homotopy given by F according to lemma 3.6 will be denoted by H^F .

The preimage $S := F^{-1}(\Delta)$ is a proper submanifold of $M \times I \times N$. Because $f_1(M) \cap f_2(N) = \emptyset$ and $\text{pr}'_2 \circ F_1(M \times \{1\}) \subset \mathbb{R}_{>f_2}$ no point of $\partial(M \times I \times N)$ will be mapped to Δ . That is why S is a closed manifold and represents an element of Ω_{n+m-q} (the induced structure on S will be explained in more detail in 3.10). Since both $M \times I$ and N are compact, the coincidence manifold S is compact and thus has only finitely many path components S_i .

If $\omega_i \in \pi_1(Q, *)$ then $[\omega_i]$ denotes a certain double coset space in $\pi_1(Q, *)$. Our aim is to assign a “weight” $[\omega_i]$ to each S_i . This leads to a refinement of the classical α -invariant.

Let us now explain the construction of $[\omega_i]$. Choose a point $s_i \in S_i$ together with a path $\beta : I \rightarrow (M \times I) \times N$, which connects $(*_1, 0, *_2)$ to s_i . Then $F \circ \beta$ is a path in $(Q \times \mathbb{R})^2$ connecting $(\bar{*}_1, \bar{*}_2)$ to $F(s_i) \in \Delta$. We define:

$$\bar{\beta}_1 := \text{pr}_1 \circ F(\beta) \quad \text{and} \quad \bar{\beta}_2 := \text{pr}_2 \circ F(\beta),$$

where $\text{pr}_i : (Q \times \mathbb{R}) \times (Q \times \mathbb{R}) \rightarrow (Q \times \mathbb{R})$, $(x_1, x_2) \mapsto x_i$ for $i = 1, 2$, are the canonical projections to the first and second factor, resp.

This yields an element $\bar{\omega}_i$ connecting $\bar{*}_1$ to $\bar{*}_2$ as follows: First go along $\bar{\beta}_1$ to the image $\bar{s}_i := \text{pr}_1 \circ F(s_i) \in (Q \times \mathbb{R})$. Then go to $\bar{*}_2$ along $\bar{\beta}_2^{-1}$ (note that F was assumed to be a b -Approximation). We define ω_i to be the image of $\bar{\omega}_i$ under $\text{pr}'_1 : Q \times \mathbb{R} \rightarrow Q$, $(q, t) \mapsto q$, i.e. $\omega_i \in \pi_1(Q, *)$ because $\text{pr}'_1(\bar{*}_1) = \text{pr}'_1(\bar{*}_2) = \bar{*}$. By summing up over all path components S_i of S we get an element of the group ring $\Omega_{p+q-n}[\pi_1(Q, *)]$. The group ring consists of all finite formal sums

Figure 3.2. Definition of $\bar{\omega}_i$ if $F_1 \times f_2$ is already transverse to Δ

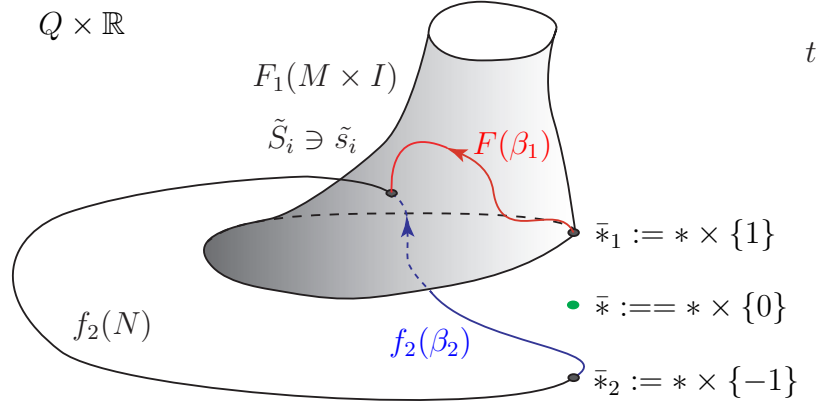

of $[S]\omega$, where $[S]$ denotes the bordism class of S in Ω_{p+q-n} and $\omega \in \pi_1(Q, *)$.

If for example $F_1 \times f_2$ is already transverse to $\Delta \in (Q \times \mathbb{R})^2$, then $\bar{\omega}_i$ is equal to $F_1(\beta_1) \cdot f_2(\beta_2^{-1})$, where $\beta = (\beta_1, \beta_2) : I \rightarrow (M \times I) \times N$ as defined above (see figure 3.2.).

Since there is no canonical choice of β we have to reduce ω_i to a coset space of $\pi_1(Q, *)$. Let us explain this in more detail. Assume β' is another choice of a path in $M \times I \times N$ connecting $(*_1, 0, *_2)$ to s_i . Then β' differs from β by a closed loop: $\beta' = \beta' \cdot \beta^{-1} \cdot \beta =: \gamma \cdot \beta$ (figure 3.3.). Now the image of γ under

Figure 3.3. Difference between two choices of β

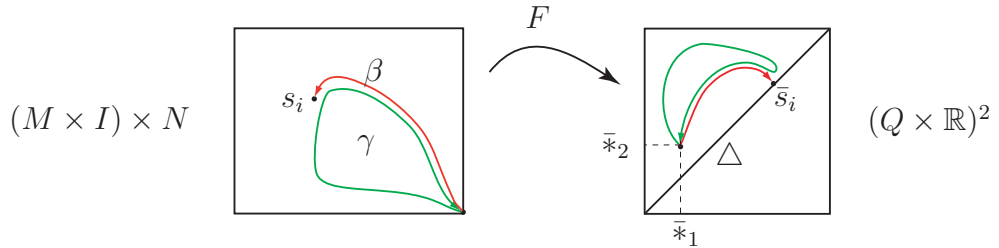

$F_1 \times f_2$ leads to a path $\bar{\gamma}$ which is homotopic to $F(\gamma)$ rel $\{0, 1\}$ by H^F restricted to γ (H^F is a b -approximation; thus H^F leaves the base point of γ fixed). For

$\bar{\gamma} = (\bar{\gamma}_1, \bar{\gamma}_2) : (M \times I) \times N \rightarrow (Q \times \mathbb{R})^2$ this results in:

$$\begin{aligned}
\bar{\beta}'_1 \cdot (\bar{\beta}'_2)^{-1} &= (\text{pr}_1 \circ F)(\beta') \cdot (\text{pr}_2 \circ F)(\beta'^{-1}) = (\text{pr}_1 \circ F)(\gamma \cdot \beta) \cdot (\text{pr}_2 \circ F)(\beta^{-1} \cdot \gamma^{-1}) \\
&= (\text{pr}_1 \circ F)(\gamma) \cdot (\text{pr}_1 \circ F)(\beta) \cdot (\text{pr}_2 \circ F)(\beta^{-1}) \cdot (\text{pr}_2 \circ F)(\gamma^{-1}) \\
&\simeq (\text{pr}_1 \circ H_1^F)(\gamma) \cdot (\text{pr}_1 \circ F)(\beta) \cdot (\text{pr}_2 \circ F)(\beta^{-1}) \cdot (\text{pr}_2 \circ H_1^F)(\gamma^{-1}) \\
&= F_1(\tilde{\gamma}_1) \cdot \bar{\beta}_1 \cdot \bar{\beta}_2^{-1} \cdot f_2(\tilde{\gamma}_2^{-1}) \\
&\simeq f_1(\text{pr}_M(\tilde{\gamma}_1)) \cdot \bar{\omega}_i \cdot f_2(\tilde{\gamma}_2^{-1}).
\end{aligned} \tag{3.1}$$

Here $\text{pr}_M : M \times I \rightarrow M, (m, t) \mapsto m$ denotes the canonical projection onto M which is a homotopy equivalence. Thus the quotient of $(Q, *)$ which we have to choose for ω_i seems to be $(\text{pr}'_1 \circ f_1)_{\#}(\pi_1(M, *_1)) \setminus \pi_1(Q, *) / (\text{pr}'_1 \circ f_2)_{\#}(\pi_1(N, *_2))$.

But the subgroup $(\text{pr}'_1 \circ f_1)_{\#}(\pi_1(M, *_1))$ does only depend on the homotopy class $[f_1] = \sigma_1 \in [(M, *_1), (Q \times \mathbb{R}, (*, 1))]$. This follows easily because any base point preserving homotopy H of f_1 to f'_1 yields $f_{1\#}(\pi_1(M, *_1)) = f'_{1\#}(\pi_1(M, *_1))$. Therefore we write $\bar{\sigma}_1$ for $(\text{pr}'_1 \circ f_1)_{\#}(\pi_1(M, *_1))$ (a subgroup of $\pi_1(Q, *)$). Likewise let $\bar{\sigma}_2$ be the subgroup of $\pi_1(Q, *)$ according to $(\text{pr}'_1 \circ f_2)_{\#}(\pi_1(N, *_2))$. Now we have collected all information to formulate the central

Definition 3.9. Let $\Lambda_{(\bar{\sigma}_1, \bar{\sigma}_2)}$ denote the double coset space

$\bar{\sigma}_1 \setminus \pi_1(Q) / \bar{\sigma}_2$. Then the *weighted linking number* α_w will be defined by:

$$\begin{aligned}
\alpha_w : \mathcal{BLM}_{(\sigma_1, \sigma_2)} &\rightarrow \Omega_{p+q-n} [\Lambda_{(\bar{\sigma}_1, \bar{\sigma}_2)}], \\
f_1 \sqcup f_2 &\mapsto \sum_i [S_i][\omega_i].
\end{aligned}$$

In section 3.3 we will prove that α_w is well-defined.

Remark 3.10 (S with structure according to Ω_*). We want to look closely at the coincidence manifold S . How can we get a canonical orientation or stable framing from our setting? The answer is given by the following sequence

of canonical bundle isomorphisms over S which we will discuss below:

$$\begin{aligned}
T(M \times I \times N)|_S &\cong TS \oplus \nu(S, M \times I \times N) \\
&\cong TS \oplus (F|_S)^*(\nu(\Delta, (Q \times \mathbb{R}) \times (Q \times \mathbb{R}))) \\
&\cong TS \oplus (F|_S)^*(\text{pr}_1^*(T(Q \times \mathbb{R}))) \\
&\cong TS \oplus ((\text{pr}_1 \circ F)|_S)^*(T(Q \times \mathbb{R}))
\end{aligned} \tag{3.2}$$

2nd row: The heart of equation 3.2 is the isomorphism between the normal bundle of S and the pullback of the normal bundle of Δ . This is based on the fact that F is transverse to Δ . Therefore we obtain a vector bundle map between the two normal bundles induced by the differential $T(F)$:

$$\begin{array}{ccc}
T(M \times I \times N)|_S / TS & \xrightarrow{T(F)} & T((Q \times \mathbb{R})^2)|_\Delta / T\Delta \\
\downarrow \nu & & \downarrow \nu \\
S & \xrightarrow{F} & \Delta.
\end{array}$$

Because of the universal property of the induced bundle we get the desired canonical isomorphism.

3rd row: This is given by the following canonical isomorphism:

$$\begin{aligned}
\psi : \text{pr}_1^*(T(Q \times \mathbb{R})) &\rightarrow \nu(\Delta, (Q \times \mathbb{R})^2), \\
((x, x), (x, v)) &\mapsto ((x, x), (v, -v)),
\end{aligned} \tag{3.3}$$

where $x \in Q \times \mathbb{R}$ and $v \in T_x(Q \times \mathbb{R})$.

Let $I \subset \mathbb{R}$ be equipped with the standard orientation and let M , N and $Q \times \mathbb{R}$ be oriented. Then we orient S or TS such that the image of the orientations on the right side under the isomorphism of 3.2 gives the orientation on the left.

To get a stable normal framing we first observe that stable normal framings are in 1-1 correspondence with stable tangential framings (see 2.7).

If we have trivializations $TN \oplus \varepsilon^{k_1} \cong \varepsilon^{n+k_1}$, $TM \oplus \varepsilon^{k_2} \cong \varepsilon^{m+k_2}$ and $T(Q \times \mathbb{R}) \oplus \varepsilon^{k_3} \cong \varepsilon^{q+1+k_3}$, the Whitney sum with a trivial bundle ε^k of large dimension $k \geq$

$\{k_1 + k_2, k_3\}$ on both sides in equation 3.2 will produce canonical isomorphisms:

$$\begin{aligned}
T(M \times I \times N) \oplus \varepsilon^k &\cong \text{pr}_1^*(TM) \oplus \varepsilon^{k_1} \oplus \text{pr}_2^*(TI) \oplus \text{pr}_3^*(TN) \oplus \varepsilon^{k-k_1} \\
&\cong \text{pr}_1^*(TM \oplus \varepsilon^{k_1}) \oplus \varepsilon^1 \oplus \text{pr}_3^*(TN \oplus \varepsilon^{k-k_1}) \\
&\cong \varepsilon^{m+k_1} \oplus \varepsilon^1 \oplus \varepsilon^{n+k-k_1} \cong \varepsilon^{m+n+1+k}
\end{aligned} \tag{3.4}$$

and

$$\begin{aligned}
TS \oplus (F_1 \circ \text{pr}_1 | S)^*(T(Q \times \mathbb{R})) \oplus \varepsilon^k \\
&= TS \oplus ((\text{pr}_1 \circ F)|S) * (T(Q \times \mathbb{R}) \oplus \varepsilon^{k_3}) \oplus \varepsilon^{k-k_3} \\
&\cong TS \oplus \varepsilon^{q+1+k_3} \oplus \varepsilon^{k-k_3} \\
&\cong TS \oplus \varepsilon^{q+1+k}.
\end{aligned} \tag{3.5}$$

This yields a stable tangential framing of S if we take the induced subbundle isomorphism in (3.4) and make use of equation (3.2).

Remark 3.11. If $F_1 \times f_2$ is already transverse to Δ , we can replace F by $F_1 \times f_2$. This results in

$$\begin{aligned}
TS \oplus ((F_1 \times f_2) \circ \text{pr}_1)^*(T(Q \times \mathbb{R})) \\
&\cong TS \oplus ((\text{pr}_1 \circ F_1)|_S)^*(T(Q \times \mathbb{R})),
\end{aligned}$$

or, equivalently, in

$$\begin{aligned}
TS \oplus ((F_1 \times f_2) \circ \text{pr}_2)^*(T(Q \times \mathbb{R})) \\
&\cong TS \oplus ((\text{pr}_2 \circ f_2)|_S)^*(T(Q \times \mathbb{R})).
\end{aligned}$$

The second isomorphism will give the same orientation as in the first case. Using the canonical identification $\text{pr}_2^*(T(Q \times \mathbb{R})) \cong \nu(\Delta)$ is exactly the same map:

$$((x, x), (x, v)) \mapsto ((x, x), (v, -v)),$$

where $x \in (Q \times \mathbb{R})$ and $v \in T_x(Q \times \mathbb{R})$.

Remark 3.12. In order to understand the geometric meaning of the above description, choose embeddings $i_1 : M \hookrightarrow S^{l_1}$, $i_2 : N \hookrightarrow S^{l_2}$ and $i_3 : (Q \times \mathbb{R}) \hookrightarrow S^{l_3}$. (By the embedding theorem of WHITNEY [Whi44] it is sufficient to take k_i twice the dimensions of M , N , $Q \times \mathbb{R}$.) Now there is a map for each pair $p, q \in \mathbb{N}$:

$$\begin{aligned} \mathbb{R}^{p+1} \times \mathbb{R}^{q+1} \supset e : S^p \times B^{q+1} &\hookrightarrow S^{p+q+1} = \mathbb{R}^{p+q+1} \cup \{\infty\}, \\ (x, y) &\mapsto ((1 + \epsilon y_1)x, \epsilon y_2, \dots, \epsilon y_q + 1), \end{aligned}$$

where $\epsilon > 0$ is small enough (e.g. $1/2$) to ensure that we get an embedding. The normal bundle given by this embedding has a canonical framing by the outer normal vectors (see figure 3.4.). Consider the restriction of

Figure 3.4. Kervaire embedding of $S^p \times B^{q+1}$ in $S^{p+q+1} = \mathbb{R}^{p+q+1} \cup \{\infty\}$

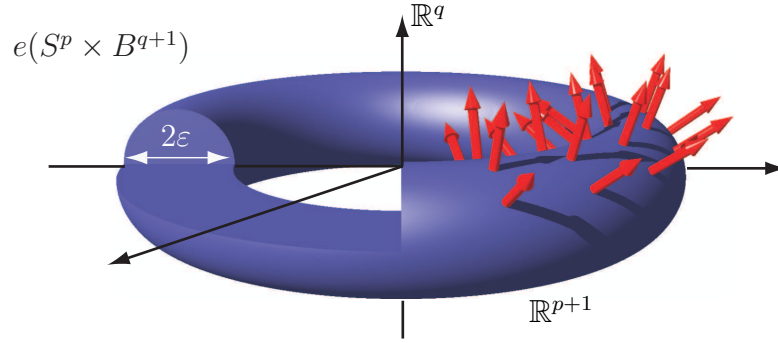

e to $\bar{e} : S^{l_1} \times (I \times S^{l_2}) \rightarrow S^{l_1+l_2+1}$, where $I \times S^{l_2}$ is a collar of $\partial B^{l_2+1} \subset B^{l_2+1}$. We take the composition of $i_1 \times Id \times i_2$ and \bar{e} to get an embedding $i : M \times I \times N \hookrightarrow S^{l_1} \times I \times S^{l_2} \hookrightarrow S^{l_1+l_2+1}$. Now choose a framing of $M \hookrightarrow S^{l_1}$, $N \hookrightarrow S^{l_2}$ by (v_1, \dots, v_{l_1-m}) and (w_1, \dots, w_{l_2-n}) , resp., such that these framings correspond to the given stable tangential framings in Remark 3.10. Thus we obtain a canonical framing of the normal bundle of $i(M \times I \times N) \subset S^{l_1+l_2+1}$ by $(v_1, \dots, v_{l_1-m}, w_1, \dots, w_{l_2-n})$. Likewise a normal framing $z_1, \dots, z_{l_3-(q+1)}$ of $Q \times \mathbb{R} \hookrightarrow S^{l_3}$ leads to a canonical framing $(z_1, \dots, z_{l_3-(q+1)}, z_1, \dots, z_{l_3-(q+1)}, n')$ of $(Q \times \mathbb{R})^2 \hookrightarrow S^{2l_3+1}$. The normal bundle of $S \subset M \times I \times N \hookrightarrow S^{l_1+l_2+1}$ is the Whitney sum of $\nu(S \hookrightarrow M \times I \times N)$ and $\nu(M \times I \times N \hookrightarrow S^{l_1+l_2+1})|_S$. So S

receives a (stable) framing in $S^{l_1+l_2+1}$ by a framing of $S \subset M \times I \times N$ together with the framing $(v_1, \dots, v_{l_1-m}, w_1, \dots, w_{l_2-n})$ above. Now by transversality we have the vector bundle map (fiberwise isomorphism):

$$TF : \nu(S \hookrightarrow M \times I \times N) \longrightarrow \nu(\Delta, (Q \times \mathbb{R})^2).$$

So the inverse of the differential dF transports a frame over $F(s) \in \Delta \subset (Q \times \mathbb{R})^2$ to a frame over $s \in S \subset M \times I \times N$.

Eventually a framing of $\text{incl}_2 : (Q \times \mathbb{R}) \hookrightarrow (Q \times \mathbb{R})^2$ (embedded canonically as the second factor) leads to a framing of $\Delta \subset (Q \times \mathbb{R})^2$, because

$$\begin{aligned} \nu(\text{incl}_2 : (Q \times \mathbb{R}) \hookrightarrow (Q \times \mathbb{R})^2) &\cong \nu(\Delta \hookrightarrow (Q \times \mathbb{R})^2), \\ ((0, x), (v, 0)) &\mapsto ((x, x), (v, -v)), \end{aligned}$$

the same map as in (3.3). But now it is clear, that

$$\nu((Q \times \mathbb{R}) \hookrightarrow S^{2l_3+1}) \cong \nu((Q \times \mathbb{R}) \hookrightarrow (Q \times \mathbb{R})^2) \oplus \nu((Q \times \mathbb{R})^2 \hookrightarrow S^{2l_3+1}).$$

So we choose a framing on $\text{incl}_2(Q \times \mathbb{R})$, such that the result of putting it together with the given framing of $(Q \times \mathbb{R})^2$ is equal to the given stabilized framing of $Q \times \mathbb{R}$.

Both descriptions are dual to each other up to a fixed sign, i.e. the induced stable normal framing of S described above corresponds via Theorem 2.7 to the stable tangential framing which we get by equation (3.4) and (3.5) up to a fixed sign.

3.3 Homotopy invariance of α_w

In this section we will prove that α_w is a well-defined map of $BLM_{M,N}^Q$, i.e. α_w is link homotopy invariant. The proof is very technical and will be given in three steps:

- independence of the choices of β and s_i ,
- independence of the choice of F_1 and the transverse approximation of F_1 ,
- (based) link homotopy invariance of α_w .

Lemma 3.13. *Let $S = \cup S_i$ be the decomposition of the coincidence manifold S into path components. Then the value of $\alpha_w(f_1 \sqcup f_2) \in \bar{\sigma}_1 \setminus \pi_1(Q) / \bar{\sigma}_2$ does not depend on the choices of $s_i \in S_i$ and β_i in $M \times I \times N$ connecting $(*_1, 0, *_2)$ to $s_i \in S_i$.*

PROOF. It is enough to prove the statement for one path component S_i of S . Choose $s_i \in S_i$. By the computation in (3.1) we proved that two distinct paths in $M \times I \times N$ connecting $(*_1, 0, *_2)$ to s_i yield the same coset space in $\bar{\sigma}_1 \setminus \pi_1(Q) / \bar{\sigma}_2$. So it remains to show the following: If $s'_i \in S_i$ is another point then we construct a special path β' to s'_i with $[\omega'_i] = [\omega_i] \in \bar{\sigma}_1 \setminus \pi_1(Q) / \bar{\sigma}_2$, where $\bar{\omega}_i$ comes from β being a path from $(*_1, 0, *_2)$ to s_i . To do this we choose a path δ in S_i connecting s_i to s'_i and define $\beta' := \beta \cdot \delta$. We compute:

$$\begin{aligned}
\bar{\omega}'_i &= (\text{pr}_1 \circ F)(\beta \cdot \delta) \cdot (\text{pr}_2 \circ F)(\delta^{-1} \cdot \beta^{-1}) \\
&= (\text{pr}_1 \circ F)(\beta) \cdot (\text{pr}_1 \circ F)(\delta) \cdot (\text{pr}_2 \circ F)(\delta^{-1}) \cdot (\text{pr}_2 \circ F)(\beta^{-1}) \\
&= (\text{pr}_1 \circ F)(\beta) \cdot (\text{pr}_1 \circ F)(\delta) \cdot (\text{pr}_1 \circ F)(\delta^{-1}) \cdot (\text{pr}_2 \circ F)(\beta^{-1}) \quad (3.6) \\
&= (\text{pr}_1 \circ F)(\beta) \cdot (\text{pr}_1 \circ F)(\delta \cdot \delta^{-1}) \cdot (\text{pr}_2 \circ F)(\beta^{-1}) \\
&\simeq (\text{pr}_1 \circ F)(\beta) \cdot (\text{pr}_2 \circ F)(\beta^{-1}) = \bar{\omega}_i.
\end{aligned}$$

Note that the third equality holds because $F(\delta) \in \Delta$, i.e. $(\text{pr}_1 \circ F)(\delta) = (\text{pr}_2 \circ F)(\delta)$.

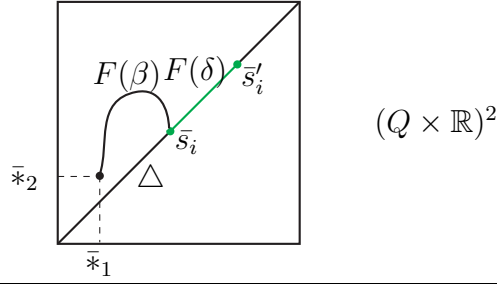
Figure 3.5. $\bar{\omega}'_i \simeq \bar{\omega}_i \text{ rel } \{0, 1\}$.

Remark 3.14. It could be concluded mistakenly that our “weighting” could be trivial, i.e. the weights are equal for all path components: Because M and N are connected, choose a path δ connecting $s_i \in S_i$ to $s_j \in S_j$ ($i \neq j$) in $M \times I \times N$. Then the computation in (3.6) shows that $[\omega_j] = [\omega_i]$. But in this case the proof is wrong. It is essential for the third equality in (3.6) that δ is a path in S_i .

The next lemma is the heart of the proof of the invariance of α_w . Before we state the lemma we introduce the following notation: If F_1 is a homotopy of f_1 to compute $\alpha_w(f_1 \sqcup f_2)$ we will write $\alpha_w(F_1, f_2)$ for the value computed by using F_1 . If H is an bh -approximation of $F_1 \times f_2$ to compute $\alpha_w(F_1, f_2)$, then $\alpha_w(H)$ indicates that we use H to compute $\alpha_w(F_1, f_2)$.

Lemma 3.15 (independence of homotopy of f_1). *Let $F_1, F'_1 : M \times I \rightarrow Q \times \mathbb{R}$ be homotopies of f_1 , such that the following terms are complied: $F_1(x, 0) = F'_1(x, 0) = f_1(x)$ and $F_1(M \times \{1\}), F'_1(M \times \{1\}) \subset Q \times \mathbb{R}_{>f_2}$. Then it follows that*

$$\alpha_w(F_1, f_2) = \alpha_w(F'_1, f_2).$$

PROOF. In a **first step** we observe that the value of α_w is independent from the choice of smooth bh -approximations of $F_1 \times f_2$ transverse to Δ . Suppose we have two sufficiently good bh -approximations $H_0 \pitchfork \Delta$ and $H_1 \pitchfork \Delta$ of $F_1 \times f_2$. We know that $H_0(x) = H_1(x) = (F_1 \times f_2)(*_1, 0, *_2)$ for all x in a small neighborhood of $(*_1, 0, *_2)$ (compare 3.5). Because H_0 and H_1 are h -Approximations, there is a b -homotopy $h : ((M \times I) \times N) \times I \rightarrow (Q \times \mathbb{R})^2$ from H_0 to H_1 , e.g.

deform H_0 to $F_1 \times f_2$ and then $F_1 \times f_2$ to H_1 by the homotopies given in lemma 3.6. Furthermore we can assume $h_t(x) := h(x, t) = H_0(x)$ for $t \in [0, \varepsilon]$ and $h_t(x) = H_1(x)$ for $t \in [1 - \varepsilon, 1]$ (ε sufficiently small; technical reasons).

Let \bar{h} be an approximation of h , smooth and transverse to Δ - the diagonal of $(Q \times \mathbb{R})^2$. Note that h is already smooth and transverse to Δ in a neighborhood U_1 of $(*_1, 0, *_2) \times I$ and U_2 of the boundary part $((M \times I) \times N) \times \{0, 1\}$. Therefore we can assume that $\bar{h}(x) = h(x)$ for $x \in \bar{U}'_1 \cup \bar{U}'_2$, where $U'_i \subset U_i$ are open with $\bar{U}'_i \subset U_i$ for $i = 1, 2$ ([GG80], Corollary 4.12).

Now we use the preimage $\bar{S} = \bar{h}^{-1}(\Delta)$ to establish a bordism between the coincidence manifolds $S^0 := \bar{h}_0^{-1}(\Delta) = H_0^{-1}(\Delta)$ and $S^1 := \bar{h}_1^{-1}(\Delta) = H_1^{-1}(\Delta)$. There are three different types of path components of \bar{S} (see figure 3.6.):

- closed components in the interior of $(M \times I) \times N \times I$,
- components with boundary only in $(M \times I) \times N \times \{0\}$ (or only in $(M \times I) \times N \times \{1\}$),
- path components with boundary in both ends.

In the case of unoriented link maps it is clear that S^0 and S^1 represent closed (unoriented) manifolds to compute $\alpha_w(H_0)$ and $\alpha_w(H_1)$, resp., and \bar{S} yields an (unoriented) bordism between them. If we consider oriented or framed link maps we have to care about the structures of S^0 and S^1 . So let \bar{S}_i be the path components of \bar{S} . Further we denote by $S^0_{i,1}, \dots, S^0_{i,k_i}$ and $S^1_{i,1}, \dots, S^1_{i,l_i}$ the boundary components of \bar{S}_i which belong to S^0 and S^1 , respectively. Consider the orientation equation (3.2) to calculate α_w . An analogous equation can be deduced for \bar{S} :

$$\varphi : T(M \times I \times N \times I)|_{\bar{S}} \cong T\bar{S} \oplus (\text{pr}_1 \circ \bar{h})|_{\bar{S}^*}(T(Q \times \mathbb{R})).$$

Remember that we orient $T\bar{S}$ such that φ is an orientation preserving isomorphism of the fiber over $s \in \bar{S}$. Now we use the orientation convention described in section 2.1. Let $\bar{S}^0_{i,j}, \bar{S}^1_{i,j'}$ be the boundary components of \bar{S}_i equipped with

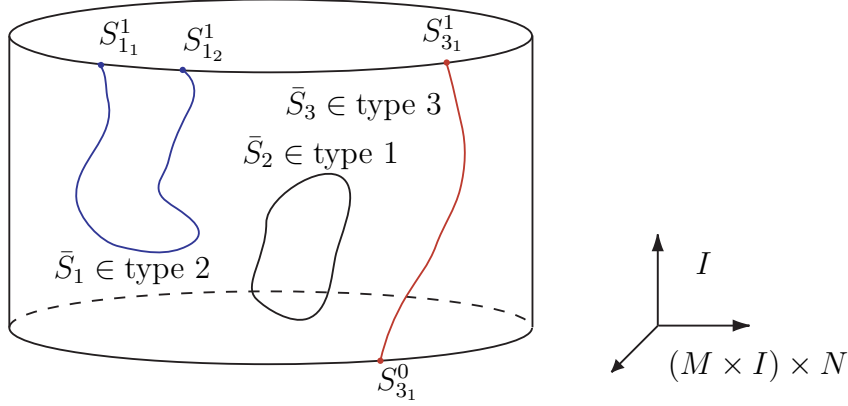
Figure 3.6. Types of path components of \bar{S} .

the orientation induced by \bar{S}_i . In view of definition 2.1 it is clear, that

$$\left[\bigcup_{j=1}^{k_i} \bar{S}_{i,j}^0 \right] = - \left[\bigcup_{j'=1}^{l_i} \bar{S}_{i,j'}^1 \right] \in \Omega_{n+m-q}^{SO}.$$

Now we use our assumption on \bar{h} near the boundary: $\bar{h}_t(x) = h_t(x) = H_0(x)$, $t \in [0, \varepsilon]$ and $\bar{h}_t(x) = h_t(x) = H_1(x)$, $t \in [1 - \varepsilon, 1]$. This ensures that the isomorphism φ restricted to the boundary of $T(M \times I \times N \times I)$ is still orientation preserving, if we orient $\partial(M \times I \times N \times I)$ and $\partial\bar{S}$ with induced orientations of $M \times I \times N \times I$ and \bar{S} , resp. To verify this let v_1, \dots, v_{n+m+2} be an oriented basis of the tangent space $T_x(M \times I \times N \times I)$ over $x \in M \times I \times N \times \{i\}$, $i = 0, 1$, and $s_1, \dots, s_{n+m-q+1}, n_1, \dots, n_{q+1}$ an oriented basis of $T_x\bar{S} \oplus (\text{pr}_1 \circ \bar{h})|_x^*(T(Q \times \mathbb{R}))$ induced by φ . Rotating the first vector “outwards” leads to the induced orientation of $M \times I \times N \times \{i\}$ (see section 2.1). But the same is true for \bar{S}^i , $i = 0, 1$, because this rotation can be done by a rotating only vectors of $s_1, \dots, s_{m+n-q+1}$ (n_1, \dots, n_{q+1} are all tangent vectors of the boundary $M \times I \times N \times \{i\}$ because the differential vanishes in the direction of the last factor!).

If we speak of $S_{i,j}^0$ and $S_{i,j'}^1$ as oriented, we fit out these manifolds with the orientation induced by equation (3.2) for S^0 and S^1 , resp.,

$$\psi_i : T(M \times I \times N)|_{S^i} \cong TS^i \oplus (\text{pr}_1 \circ H_i)^*(T(Q \times \mathbb{R})), \quad \text{for } i = 0, 1.$$

Note that $H_0(x) = h_t(x)$ for all $x \in M \times I \times N$ and $t \in [0, \varepsilon]$, so it follows that the differential involved in ψ_0 is simply $\varphi|(TM \times I \times N \times \{0\})$. The same is true for ψ_1 . Again following the orientation convention discussed in section 2.1 we conclude that either S^0 carries the same orientation as \bar{S}^0 or S^1 carries the same orientation of \bar{S}^1 . This is due to the fact that if we use the orientation conventions for products and boundaries then $M \times I \times N \times \{0\} = \pm M \times I \times N$ and $M \times I \times N \times \{1\} = \mp M \times I \times N$. The upper sign in both equations is true if $n + m$ is odd and the lower sign is true if $n + m$ is even (where $=$ means orientation preserving diffeomorphic). This yields:

$$\sum_{j=1}^{k_i} [S_{i,j}^0] = \pm \sum_{j=1}^{k_i} [\bar{S}_{i,j}^0] = \mp \sum_{j'=1}^{l_i} [\bar{S}_{i,j'}^1] = \sum_{j'=1}^{l_i} [S_{i,j'}^1] \quad (3.7)$$

in Ω_{n+m-q}^{SO} .

The same argument works in the stably framed category. Here we use equations (3.4) and (3.5) which shows that our induced stable (tangential) framing of the coincidence manifold S depends only on the isomorphism described by equation (3.2) and the stable framings of M , N and Q . Because of our framing conventions in section 2.1 and remark 2.4 it is easy to see that stable (normal) framings induced on the boundary components $M \times I \times N \times \{0\}$ and $M \times I \times N \times \{1\}$ behaves in a same manner as orientations described above. So we establish equation (3.7) in the framed case Ω_{n+m-q}^{fr} .

This proves the first part of step one. Now we want to look at the weightings:

Claim 3.16. Let $[\omega_{i,j}^0] = [\omega_{i,j'}^0] = [\omega_{i,j''}^1] =: [\omega_i]$ for all $j, j' \in \underline{k_i}$ and $j'' \in \underline{l_i}$.

Then it follows:

$$\begin{aligned} 0 &= \left(\sum_i ([S_i^0] + [-S_i^1]) \right) [\omega_i] = \sum_i \left(\left(\sum_{j=1}^{k_i} [S_{i,j}^0] [\omega_{i,j}^0] \right) - \left(\sum_{j'=1}^{l_i} [S_{i,j'}^1] [\omega_{i,j'}^1] \right) \right) \\ &= \alpha_w(H_0) - \alpha_w(H_1). \end{aligned} \quad (3.8)$$

So we have shown that $\alpha_w(F_1, f_2)$ is a well-defined notation: α_w does not depend on the bh -approximation of $F_1 \times f_2$.

PROOF (PROOF OF CLAIM 3.16). To simplify notations we first assume that S is connected with $\partial S = S_1^0 \cup S_2^0 \cup S_1^1$ (the generalization to more components of S and ∂S can be proven analogously).

According to the construction of ω_1^0 , we have a representative $\bar{\omega}_1^0 : I \rightarrow Q \times \mathbb{R}$ connecting $\bar{*}_1$ and $\bar{*}_2$: $\bar{\omega}_1^0 = (\text{pr}_1 \circ H_0)(\beta) \cdot (\text{pr}_2 \circ H_0)(\beta^{-1})$, where $\beta : I \rightarrow M \times I \times N$ connects $(*_1, 0, *_2)$ to s_1^0 . Now choose $s_1^1 \in S^1$ and a path $\delta : I \rightarrow (M \times I \times N) \times I$ with $\delta(0) = s_1^0$ and $\delta(1) = s_1^1$ (such a path exists because S is path connected). Consider the homotopy $h' : \{0, 1\} \times I \rightarrow (M \times I \times N) \times I$ given by $h'_t(1) = \delta(t)$ and $h'_t(0) = (\beta(0), t)$. Because $i : \{0, 1\} \hookrightarrow I$ is a

Figure 3.7. $h' \cdot h''$, where h'' is restricted to $h'_1(I)$.

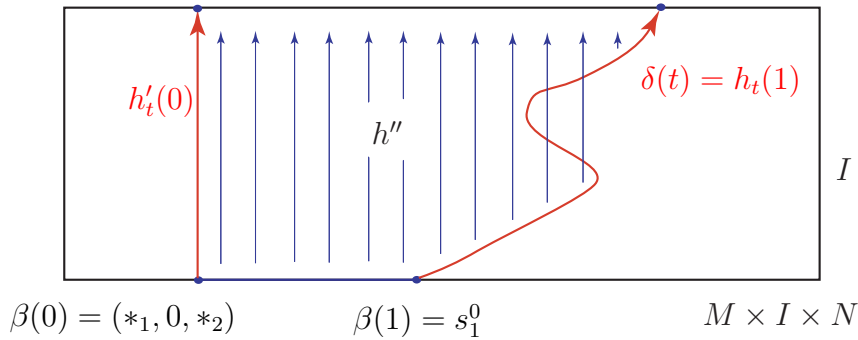

(closed) cofibration we can extend h to all of I . The canonical deformation h'' of $(M \times I \times N) \times I$ to $(M \times I \times N) \times \{1\}$ restricted to $h'_1(I)$ yields a homotopy to $\beta' : I \rightarrow (M \times I \times N) \times \{1\}$, where $\beta'(0) = (\beta(0), 1)$ and $\beta'(1) = \delta(1) = s_1^1$. The composition is $h' \cdot h''$ is depicted in figure 3.7.. By lemma 3.13 the path β' as a path in $M \times I \times N$ is a possible choice to compute $[\omega_1^1]$. Because the homotopy \bar{h} was assumed to be base point preserving and constant in a neighborhood $U'_1 \supset (*_1, 0, *_2) \times I$, the image of $h' \cdot h''$ under \bar{h} yields a homotopy of $H_0(\beta) \cdot H_0(\beta^{-1})$ to $H_1(\beta') \cdot H_1(\beta'^{-1}) \text{ rel } \{0, 1\}$. It follows $[\omega_1^0] = [\omega_1^1]$ by projection to $(Q, *)$.

In figure 3.8. the two different cases are shown. The proof of the second case, i.e. $[\omega_1^0] = [\omega_2^0]$ follows similarly and will be omitted.

Figure 3.8. Homotopy of $\bar{\omega}_1^1$ to $\bar{\omega}_1^0$ and $\bar{\omega}_1^1$, resp., if both H_0 and H_1 are product maps

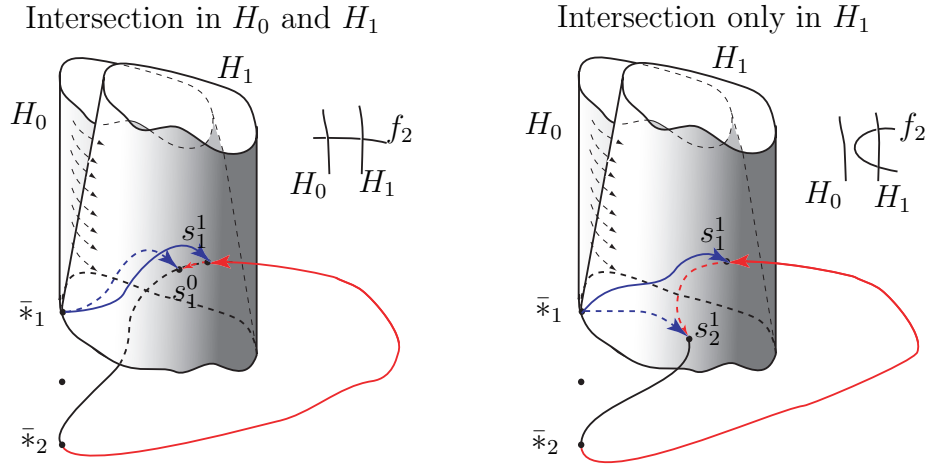

In **step two** we show the independence of the choice of F_1 in the computation of α_w . To prove this let F_1 and F'_1 be two different homotopies of f_1 . We construct the “composition” F of F_1 and F'_1 in the following way:

$$F : M \times I \rightarrow Q \times \mathbb{R}, F(x, t) := \begin{cases} F'_1(x, -2t + 1) & \text{if } 0 \leq t \leq 1/2, \\ F_1(x, 2(t - 1/2)) & \text{if } 1/2 \leq t \leq 1. \end{cases}$$

Here comes the special structure $Q \times \mathbb{R}$ in the game. Because of the \mathbb{R} -factor we can pull down the image of f_2 away from the image of F by a homotopy H such that $H_t(x) = f_2(x)$ for $t \in [0, \epsilon]$ ($\epsilon > 0$; only for technical reasons which later becomes clear). This means, that $H_1(f_2) \subset Q \times]\min\{\text{pr}_2(F(M \times I))\}, -\infty[$, where $\text{pr}_2 : Q \times \mathbb{R} \rightarrow \mathbb{R}$ is the canonical projection to the second factor. To get our coincidence manifold we have to *bh*-approximate $F \times H$ by a smooth map \bar{h} which is transverse to Δ . Note that the base point of $M \times I \times N$ is now $(*_1, 1/2, *_2)$. For our purpose we need a map \bar{h} such that \bar{h}_0 is a *bh*-approximation of $F \times H$.

Claim 3.17. There is a choice for \bar{h} as above which is constant in the last factor of $(M \times I \times N) \times I$ on $[0, \epsilon']$.

PROOF (PROOF OF THE CLAIM). The idea of the prove is similar to the proof

of lemma 3.6. First we *bh*-approximate $F \times H_0$ by a map $g : M \times I \times N \rightarrow (Q \times \mathbb{R})^2$ which is transverse to Δ . Next we embed $(Q \times \mathbb{R})^2$ by i into \mathbb{R}^k where k large and choose a tubular neighborhood $N(i((Q \times \mathbb{R})^2))$ with a retraction $r : N(i((Q \times \mathbb{R})^2)) \rightarrow i((Q \times \mathbb{R})^2)$. Now we consider a partition of unity λ_1, λ_2 subordinated to the cover $[0, \varepsilon), (\varepsilon', 1]$ of I , $0 < \varepsilon' < \varepsilon < 1$, such that $\lambda_1(t) = 1$ for $t \in [0, \varepsilon']$ and $\lambda_2(t) = 1$ for $t \in [\varepsilon, 1]$. We define

$$\begin{aligned} h : (M \times I \times N) \times I &\longrightarrow (Q \times \mathbb{R})^2 \\ (x, t) &\longmapsto \lambda_1(t)g(x) + \lambda_2(t)(F \times H)(x). \end{aligned}$$

We know that $r \circ h|(M \times I \times N \times [0, \varepsilon'])$ is already transverse to Δ : $T_{g(x)}(T(M \times I \times N)) = T_{r \circ h(x,t)}(T(M \times I \times N \times I))$ and g was assumed to be transverse to Δ . Finally we choose $\bar{h} \in C^\infty(M \times I \times N \times I)$, such that \bar{h} is a smooth *bh*-approximation of $r \circ h$ which is transverse to Δ with $\bar{h}_t(x) := \bar{h}(x, t) = g(x)$ for $t \in [0, \varepsilon']$ (this restriction is possible, compare again corollary 4.12. in [GG80]).

The map \bar{h} now plays a similar role as \bar{h} defined in the first step.

The preimage $\bar{S} := \bar{h}^{-1}(\Delta)$ is a $m + n + 2 - q - 1 = m + n - q + 1$ -dimensional manifold. Because $H(N \times I) \cap F(M \times \{0, 1\}) = \emptyset$ and $H(N \times \{1\}) \cap F(M \times I) = \emptyset$, we can assume that $\partial \bar{S} \subset M \times I \times N \times \{0\}$. By construction we establish $\bar{h}_0(x) = g(x)$. Note that $g(M \times [1/2, 1] \times N)$ is a *bh*-approximation to compute $\alpha_w(F_1, f_2)$ whereas $g(M \times [0, 1/2] \times N)$ allows to compute $\alpha_w(-F'_1, f_2)$:

$$\alpha_w(-F'_1, f_2) := \alpha_w(F'_1 \circ (\text{Id}_M \times r \times \text{Id}_N), f_2).$$

Here r denotes an orientation reversing diffeomorphism on I . Thus \bar{S} is an (unoriented) bordism between S and S' , the coincidence manifolds contributing to $\alpha_w(F_1, f_2)$ and $\alpha_w(-F'_1, f_2)$. If we are dealing with unoriented manifolds there is no difference between $\alpha_w(F'_1, f_2)$ and $\alpha_w(-F'_1, f_2)$. Thus \bar{S} leads to equation (3.7), where $\Omega_* = \mathfrak{N}_*$.

In the case of oriented or framed manifolds we have to be more carefully. As

in the first step we use the following equation to fix orientations:

$$\varphi : T(M \times I \times N \times I)|_{\bar{S}} \cong T\bar{S} \oplus (\text{pr}_1 \circ \bar{h})^*(T(Q \times \mathbb{R})).$$

The coincidence manifold \bar{S} carries the orientation such that φ is orientation preserving with respect to the product orientations on $M \times I \times N \times I$ and $Q \times \mathbb{R}$, resp.(compare again section 2.1). Now \hat{S} and \hat{S}' will be S and S' , resp., oriented as boundaries of \bar{S} whereas S and S' denote the manifolds with orientation obtained by the equations to calculate $\alpha_w(F_1, f_2)$ and $\alpha_w(-F'_1, f_2)$, resp. (compare eq. (3.2)):

$$T(M \times I \times N)|_S \cong TS \oplus ((\text{pr}_1 \circ \bar{h}_0)|_S) * (T(Q \times \mathbb{R})) \quad (3.9)$$

and

$$T(M \times I \times N)|_{S'} \cong TS' \oplus ((\text{pr}_1 \circ \bar{h}_0)|_{S'}) * (T(Q \times \mathbb{R})). \quad (3.10)$$

Because $\hat{S} \cup \hat{S}' \subset M \times I \times N \times \{0\}$, we conclude that either both are equipped with orientations different from S and S' , resp., or both are equipped with the same orientation (compare step one - both located in the same boundary component $M \times I \times N \times \{0\}$).

On the other hand one can show that $\alpha_w(F'_1, f_2) = -\alpha_w(-F'_1, f_2)$. For the differential $T\bar{h}_0|(T(M \times I \times N \times \{0\})) = Tg$ is involved to establish the bundle isomorphism φ (see equation (3.2)). That is the reason why replacing F'_1 by $-F'_1 := F'_1 \circ r$, where r is orientation reversing, leads to an orientation reversing isomorphism. To correct this we have to change the orientation of S' .

Again we denote the path components of \bar{S} by \bar{S}_i . The boundary components of \bar{S}_i with induced orientation by \bar{S} will be denoted by $\bar{S}_{i,j} \subset \hat{S}$ and $\hat{S}'_{i,j'} \subset \hat{S}'$. Summarizing the facts we deduce:

$$\sum [S_{i,j}] = \pm \sum [\hat{S}_{i,j}] = \mp \sum [\hat{S}'_{i,j'}] = - \sum [S'_{i,j}] \quad (3.11)$$

as classes in Ω_{n+m-q}^{SO} . Again the same is true for framed manifolds (compare step one for an explanation).

Notice that we needed the result of step one, i.e. that the values of α_w do not depend on the transverse approximation. By our approximation \bar{h} we used two special bh -approximations $\bar{h}_0|(M \times [1/2, 1] \times N \times \{0\})$ and $\bar{h}_0|(M \times [0, 1/2] \times N \times \{0\})$ to compute $\alpha_w(F_1, f_2)$ and $\alpha_w(-F'_1, f_2)$, respectively.

Showing that the chosen weightings (as double cosets in $\bar{\sigma}_1 \backslash \pi_1(Q, *) / \bar{\sigma}_2$) for the boundary components of each path component \bar{S}_i are the same enables us to finish the proof as in step one. Assuming this fact for a moment we obtain together with (3.11):

$$\begin{aligned} \forall i : \sum_j [S_{i,j}] [\omega_{i,j}] &= - \sum_{j'} [S'_{i,j'}] [\omega_{i,j'}] \\ \implies \alpha_w(F_1, f_2) &= -\alpha_w(-F'_1, f_2) = \alpha_w(F'_1, f_2). \end{aligned}$$

As in step one we have to study to different cases: We have to show that

- $[\omega_{i,j}] = [\omega_{i,j'}]$, i.e. $\hat{S}_{i,j} \cup \hat{S}_{i,j'} \subset \partial \bar{S}_i$, and
- $[\omega_{i,j}] = [\omega'_{j,j'}]$, i.e. $\hat{S}_{i,j} \cup \hat{S}'_{i,j'} \subset \partial \bar{S}_i$.

It is enough to prove this for the following situation: $\bar{S}_i = \hat{S}_1 \cup \hat{S}_2 \cup \hat{S}'_1$. We wish to show that $[\omega_1] = [\omega_2] = [\omega'_1]$, i.e. all boundary components of \hat{S}_i contribute to α_w with the same weighting. Let β be a path described in the construction of α_w to compute $\omega_1 \in (Q, *)$. To simplify notations we call the canonical inclusion of β into $M \times I \times N \times \{0\} \subset M \times I \times N \times I$ by β again, i.e. $\beta(0) = (*_1, 1/2, *_2, 0)$ and $\beta(1) = (s_1, 0) \in \hat{S}_1$.

Now a similar argument as in step one shows that we can construct a homotopy \bar{H} of $\bar{\omega}_1$ to some $\bar{\omega}'_1 \text{ rel } \{0, 1\}$, where $\omega'_1 := \text{pr}'_1 \circ \bar{\omega}'_1$ is a closed loop which can be used to compute the double coset according to S'_1 . Recall that $\text{pr}'_1 : Q \times \mathbb{R} \rightarrow Q$ is the canonical projection onto the first factor. Then the assertion then follows.

We start with a path δ in \bar{S}_1 which connects s_1 to s'_1 (\bar{S}_1 is connected). Now extend the homotopy $h'_t : \{0, 1\} \rightarrow M \times I \times N \times I$ given by $h'_t(0) =$

$h'_0(0) = (*_1, 0, *_2, 0)$ and $h'_t(1) = \delta(t)$ to all of I . We can do this because $\{0, 1\} \hookrightarrow I$ is a cofibration (and thus has the homotopy extension property). A second homotopy h'' is given along the canonical projection of $M \times I \times N \times I$ to $M \times I \times N \times \{0\}$ restricted to $h'_1(I)$. The result of the homotopy $h' \cdot h''$ is the path $(h' \cdot h'')_1(I)$, where $h' \cdot h''$ denotes the usual composition of homotopies (which means to apply h' first). Now we have to deform $(h' \cdot h'')_1(I) \text{ rel } \{0, 1\}$ to a path in $M \times [0, 1/2] \times N \times \{0\}$ because only this part contributes to weightings for S'_1 . This can easily be done by the canonical deformation h''' of $M \times I \times N \times \{0\}$ to $M \times [0, 1/2] \times N \times \{0\}$ (start and end point are located in $M \times [0, 1/2] \times N \times \{0\}$ already). The homotopy induced by $h' \cdot h'' \cdot h'''$ under $(\text{pr}_1 \circ \bar{h})$ and $(\text{pr}_2 \circ \bar{h})$ yields the desired homotopy \bar{H} . Here $\text{pr}_i : (Q \times \mathbb{R})^2 \rightarrow (Q \times \mathbb{R})$, $i = 1, 2$, denote the canonical projections onto the first and second factor, resp. Both homotopies

Figure 3.9. a): Homotopy \bar{H} of $\bar{\omega}$ to $\bar{\omega}'$ if \bar{h} is a product map and $F_1 \times f_2 \pitchfork \Delta$, $F'_1 \times f_2 \pitchfork \Delta$; b): h' in $M \times I \times N \times I$

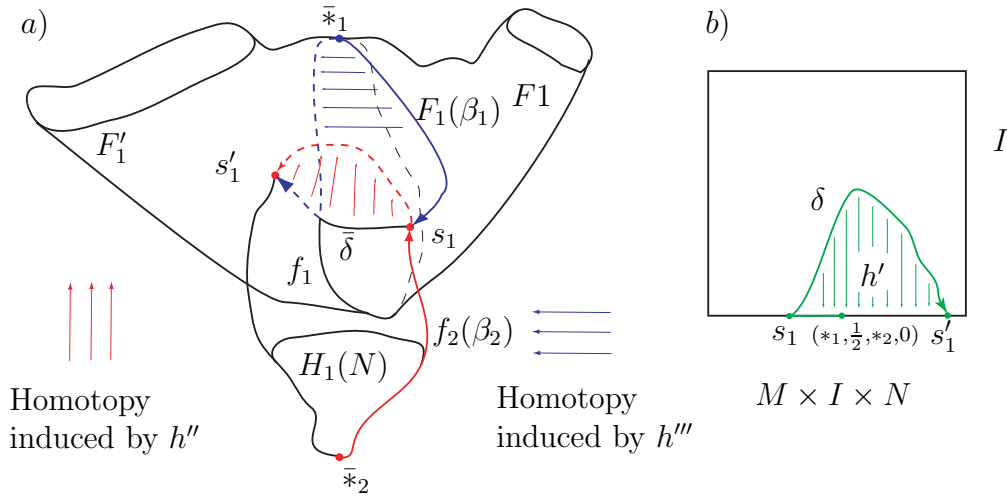

are depicted in figure 3.9. to give a better understanding of the construction. On the left hand side of figure 3.9. you can see $(\text{pr}_1 \circ \bar{h})(h' \cdot h'' \cdot h''')$ on β and $(\text{pr}_2 \circ \bar{h})(h' \cdot h'' \cdot h''')$ on β^{-1} if \bar{h} is a product map and $F_1 \times f_2$, $F'_1 \times f_2$ are already transverse to Δ . We will make use of the splitting $\beta = (\beta_1, \beta_2) : I \rightarrow (M \times I) \times (N \times \{0\})$. The sequence of homotopies can be described as follows: First pull the end of $F(\beta_1)(1) = f_2(\beta_2)(1)$ along $\bar{\delta} = (\text{pr}_1 \circ \bar{h})(\delta)$ to s'_1 (pull

both paths afterwards - which is exactly the homotopy extension induced by the canonical retraction of $I \times I$ to $(0 \times I) \cup (I \times 0) \cup (1 \times I)$ showing that $\{0, 1\} \hookrightarrow I$ is a cofibration). Let us write β'_1 and β'_2 for the paths which are the result of this homotopy. Then the homotopy induced by h'' in $(M \times I \times N) \times I$ (sketched on the right hand side of figure 3.9.) only deforms β'_2 to the dotted red path. Finally the homotopy h''' induces a homotopy of β'_1 to the dotted blue path.

The second assertion $[\omega_1] = [\omega_2]$ is modeled on the same construction. The only difference is that the last homotopy to move our path to $M \times [0, 1/2] \times N \times \{0\}$ has to be changed. In this case we have to deform $M \times I \times N \times \{0\}$ to $M \times [1/2, 1] \times N \times \{0\}$. But again this is no problem because start and end point are both in $M \times [1/2, 1] \times N \times \{0\}$. This finishes the proof of this very technical lemma.

Theorem 3.18. *The map α_w is a well-defined invariant for based link maps $f_1 \sqcup f_2 : M \sqcup N \rightarrow Q \times \mathbb{R}$ up to base point preserving link homotopy.*

PROOF. From lemma 3.15 it follows directly that the map α_w is a well-defined. Thus it remains to show that α_w does not change if we deform $f_1 \sqcup f_2$ by a base point preserving link homotopy. Because I is compact every link homotopy of $f_1 \sqcup f_2$ can be decomposed into a (finite) sequence of homotopies where only one component will be deformed in the complement of the other one (compare e.g. Lemma 2.40, [Pil97]).

So let H be a base point preserving deformation of f_1 to f'_1 in the complement of f_2 . We choose further homotopies F_1 and F'_1 to calculate α_w . If we consider $F'_1 \cdot H$ (composition of the deformations) lemma 3.15 shows that

$$\alpha_w(f_1 \sqcup f_2) = \alpha_w(F_1, f_2) = \alpha_w(F'_1 \cdot H, f_2) = \alpha_w(F'_1, f_2) = \alpha_w(f'_1 \sqcup f_2).$$

The third equality is due to the fact that H has no intersection with f_2 and H was assumed to be base point preserving.

In a second step let us deform f_2 in the complement of f_1 by a base point

preserving homotopy H . Then we can use lemma 3.15 again together with the symmetry relation (3.12), which will be established in section 3.4:

$$\begin{aligned}\alpha_w(f_1 \sqcup f_2) &= \iota(\bar{\alpha}_w(f_2 \sqcup f_1)) = \iota(\bar{\alpha}_w(F_2, f_1)) = \iota(\bar{\alpha}_w(F'_2 \cdot H, f_1)) = \\ &= \iota(\bar{\alpha}_w(f'_2 \sqcup f_1)) = \alpha_w(f_1 \sqcup f'_2).\end{aligned}$$

Here $\iota : \Omega_{m+n-q}[\Lambda_{(\bar{\sigma}_1, \bar{\sigma}_2)}] \rightarrow \Omega_{m+n-q}[\Lambda_{(\bar{\sigma}_2, \bar{\sigma}_1)}]$ denotes an homomorphism of free abelian groups which maps $[S][\omega]S$ to $(-1)^{(m+1)(n+1)+q}[S][\omega^{-1}]$. $\bar{\alpha}_w$ is constructed in the same way as α_w but using a homotopy down to f'_1 with $\text{pr}_2(f'_1(M)) \subset \mathbb{R}_{<f_2}$, compare section 3.4 where we discuss ι and $\bar{\alpha}_w$ in more detail.

3.4 Symmetry relations of α_w

In this section we discuss some symmetry relations of α_w . First there is no canonical choice to pull the image of f_1 in the positive or negative direction according to the \mathbb{R} -factor. It is surely no surprise that we obtain another invariant $\bar{\alpha}_w$ if we pull down f_1 by a homotopy $\bar{F}_1 : M \times I \rightarrow Q \times \mathbb{R}$, such that

$$(\text{pr}'_2 \circ \bar{F}_1)(M \times \{1\}) \subset \mathbb{R}_{<f_2} :=] \min\{\text{pr}'_2(f_2(x)) \mid x \in N\}, -\infty[,$$

$\text{pr}'_2 : Q \times \mathbb{R} \rightarrow \mathbb{R}$ is the projection onto the second factor (clearly, \min exists because N is compact). The proof that $\bar{\alpha}_w$ is well-defined up to (based) link homotopy of f_1 in the complement of f_2 can be modeled on the very same proof for α_w in the previous section.

Now we will detect relations between α_w and $\bar{\alpha}_w$. Let us compare $\alpha_w(f_1 \sqcup f_2)$ and $\bar{\alpha}_w(f_2 \sqcup f_1)$. Intuitively it seems to be clear that there should not be great differences between them. We can manifest this in the following theorem:

Theorem 3.19. *Let $f_1 \sqcup f_2 : M \sqcup N \rightarrow Q \times \mathbb{R}$ be a link map and define $\bar{\sigma}_1 := (\text{pr}'_1 \circ f_1)_\#(\pi_1(M, *_1))$, $\bar{\sigma}_2 := (\text{pr}'_1 \circ f_2)_\#(\pi_1(N, *_2))$. Then the following symmetry relation holds:*

$$\alpha_w(f_1 \sqcup f_2) = \iota(\bar{\alpha}_w(f_2 \sqcup f_1)), \quad (3.12)$$

where $\iota : \Omega_{n+m-q}[\Lambda_{(\bar{\sigma}_1, \bar{\sigma}_2)}] \rightarrow \Omega_{n+m-q}[\Lambda_{(\bar{\sigma}_2, \bar{\sigma}_1)}]$ is a homomorphism of abelian groups induced by $\iota([S][g]) = (-1)^{(n+1)(m+1)+q}[S][g^{-1}]$.

PROOF. It is easy to find homotopies F_1 of f_1 and F_2 of f_2 to pull first f_1 into $Q \times \mathbb{R}_{>f_2}$ and then f_2 into $Q \times \mathbb{R}_{>F_1}$. For example we may choose $m \in \mathbb{R}$, such that $\min\{\text{pr}'_2 \circ f_1(M)\} + m \in \mathbb{R}_{>f_2}$ and $\max\{\text{pr}'_2(f_2(N))\} - m \in \mathbb{R}_{<f_1}$. This is possible since both M and N are compact. Now define $F_1 : M \times I \rightarrow Q \times \mathbb{R}$ by

$$F_1(x, t) := \begin{cases} f_1(x) + (0, m\frac{4}{3}(t - \frac{1}{4})) & \text{if } t \in [\frac{1}{4}, 1], \\ f_1(x) & \text{if } t \in [0, \frac{1}{4}]. \end{cases}$$

The equality of F_1 and f_1 in $[0, \frac{1}{4}]$ is only for technical reasons and will be used later. A map $F_2 : N \times I \rightarrow (Q \times \mathbb{R})^2$ can be defined in a similar manner: $F_2(x, s) = f_2 - (0, m\frac{4}{3}(t - \frac{1}{4}))$ for $t \in [\frac{1}{4}, 1]$. The homotopies can be described by pulling f_1 up in the positive \mathbb{R} -direction and pull f_2 down in the negative \mathbb{R} -direction.

In view of lemma 3.15, we can use these homotopies to calculate $\alpha_w(f_1 \sqcup f_2)$ and $\bar{\alpha}_w(f_2 \sqcup f_1)$, respectively. To do this we consider a smooth bh -approximation H of

$$F_1 \times F_2 : (M \times I) \times (N \times I) \rightarrow (Q \times \mathbb{R}) \times (Q \times \mathbb{R})$$

transverse to the diagonal $\Delta \subset (Q \times \mathbb{R}) \times (Q \times \mathbb{R})$. Similar as in step two of the proof of lemma 3.15 we can assume that in a collar of $V_1 := (M \times I) \times N \times \{0\}$ and $V_2 := M \times \{0\} \times N \times I$ we have:

$$\begin{aligned} H(m, t, n, s) &= h_1(m, t, n) \quad \text{for } s \in [0, \varepsilon] \\ H(m, t, n, s) &= h_2(m, n, s) \quad \text{for } t \in [0, \varepsilon], \end{aligned}$$

where h_1 and h_2 are smooth bh -approximations of $F_1 \times f_2$ and $f_1 \times F_2$ resp. transverse to Δ . We can see this as follows: First bh -approximate $F_1 \times f_2$ by a smooth map h_1 transverse to Δ . Then consider

$$\begin{aligned} H_1 : M \times I \times N \times [0, \varepsilon] &\rightarrow (Q \times \mathbb{R})^2, \\ (m, t, n, s) &\mapsto h_1(m, t, n). \end{aligned}$$

The map H_1 is homotopic to $F_1 \times F_2$ restricted to $M \times I \times N \times [0, \varepsilon]$. Thus we can apply a partition of unity argument to extend H_1 to all of $M \times I \times N \times I$. Now a construction of H_2 can be done in the same way. A second partition of unity argument can be used to define \bar{H} , such that \bar{H} restricted to $M \times [\varepsilon + \delta, 1] \times N \times [0, \varepsilon]$ is equal to H_1 and H restricted to $M \times [0, \varepsilon] \times N \times [\varepsilon + \delta, 1]$ is equal to H_2 . Now bh -approximate \bar{H} by a smooth map H which is transverse to $\Delta \subset (Q \times \mathbb{R})^2$. Furthermore we can assume that on $M \times [\varepsilon + \delta, 1] \times N \times [0, \varepsilon] \cup M \times [0, \varepsilon] \times N \times [\varepsilon + \delta, 1]$ our approximation H is equal to \bar{H} . This can be done according to the following observation: If we have a compact space X

and a smooth map $f : X \rightarrow Y$ transverse to $A \subset Y$ and a map $F : X \times I \rightarrow Y$, with $F(x, t) = f(x)$ for $t \in [0, \varepsilon]$, then $F|(X \times [0, \varepsilon])$ is also transverse to A .

Now let \bar{S} be the $n+m+1-q$ -dimensional coincidence manifold $\bar{S} := H^{-1}(\Delta)$ with orientation induced by an analogous equation to (3.2):

$$\varphi : T(M \times I \times N \times I)|_{\bar{S}} \cong T\bar{S} \oplus (\text{pr}_1 \circ H)^*(T(Q \times \mathbb{R})).$$

Because

$$f_1(M) \cap f_2(N) = F_1(M \times \{1\}) \cap f_2(N) = f_1(M) \cap F_2(N \times \{1\}) = \emptyset,$$

we know that \bar{S} has only boundary components $S^1 \subset V_1$ and $S^2 \subset V_2$, $\partial\bar{S} = S^1 \cup S^2$. Again by \bar{S}^1 and \bar{S}^2 we denote the manifolds S^1 and S^2 , resp., with induced orientations. This yields

$$[\bar{S}^1] = [-\bar{S}^2]. \quad (3.13)$$

Now φ establishes a canonical isomorphism restricted to the tangent bundle $T(M \times I \times N \times \{0\})$ over \bar{S}^1 . This is the same isomorphism as in the computation of $\alpha_w(F_1, f_2)$ given by h_1 . If we now compare \bar{S}^1 to S^1 with induced orientation by the orientation preserving isomorphism:

$$\varphi| : T(M \times I \times N \times \{0\})|_{S^1} \cong TS^1 \oplus (\text{pr}_1 \circ h_1)^*(T(Q \times \mathbb{R})),$$

we conclude:

$$[S^1] = \begin{cases} [\bar{S}^1] & \text{if } n+m \text{ even,} \\ -[\bar{S}^1] & \text{if } n+m \text{ odd.} \end{cases} \quad (3.14)$$

In the first case we know that $M \times I \times N$ with product orientation is orientation preserving diffeomorphic to $M \times I \times N \times \{0\}$ with orientation induced as boundary of $M \times I \times N \times I$ with product orientation (compare discussion in section 2.1). In the second case the reverse is true.

In a next step we consider $\hat{S}^2 := S^2$ equipped with the orientation induced

by:

$$\varphi| : T(M \times \{0\} \times N \times I)|S^2 \cong TS^2 \oplus (\text{pr}_1 \circ h_2)^*(T(Q \times \mathbb{R})),$$

but $M \times \{0\} \times N \times I$ equipped with product orientation. A similar argument as above shows that:

$$[\hat{S}^2] = \begin{cases} [\bar{S}^2] & \text{if } m \text{ odd,} \\ -[\bar{S}^2] & \text{if } m \text{ even.} \end{cases} \quad (3.15)$$

Consider now the map $\bar{h}_2 : (N \times I) \times M \rightarrow (Q \times \mathbb{R}) \times (Q \times \mathbb{R})$, which is the composition:

$$(N \times I) \times M \xrightarrow{s_1} M \times (N \times I) \xrightarrow{h_2} (Q \times \mathbb{R})^2 \xrightarrow{s_2} (Q \times \mathbb{R})^2.$$

Here s_1, s_2 are the obvious maps which swap the first and second factors in the respective manifolds. The orientation equation (3.2) can be used to compute $\bar{\alpha}_w(f_2 \sqcup f_1)$. The coincidence manifold is clearly homeomorphic to S^2 by interchanging the coordinates. The orientation induced by \bar{h}_2 differs from the orientation of \hat{S}^2 by the factor $(-1)^{m(n+1)+q+1}$. The first part $(-1)^{m(n+1)}$ is the result of interchanging the tangent vectors in the product orientation of $M \times (N \times I)$. The second part $(-1)^{q+1}$ comes from s_2 and the canonical isomorphism ψ described in equation (3.3). Summarizing the results above we obtain:

$$\begin{aligned} [S^1] &= (-1)^{m+n}[\bar{S}^1] = (-1)^{m+n+1}[\bar{S}^2] = (-1)^n[\hat{S}^2] \\ &= (-1)^{n+m(n+1)+q+1}[S^2] = (-1)^{(m+1)(n+1)+q}[S^2]. \end{aligned}$$

This proves the result in the case of oriented link maps. We proceed with a similar computation for the framed case.

Now let us concentrate on the weightings. Let \bar{S}_i be the path components of \bar{S} . Again we have to deal with two types of boundary components: Two boundary components of \bar{S}_i belong either to S^1 or S^2 , or the second case where a boundary component is contained in S^1 and S^2 , resp. We assume that \bar{S} consists of one path component with three boundary components $S_1^1, S_2^1 \subset S^1$

and $S_1^2 \subset S^2$. The proof is easily finished if we can show that $[\omega_1^1] = [\omega_2^1]$ and $[\omega_1^1] = [(\omega_1^2)^{-1}]$.

We start with a path β in $M \times I \times N \times \{0\}$ which yields $\bar{\omega}_1^1 \subset Q \times \mathbb{R}$ to compute $\alpha_w(f_1 \sqcup f_2)$. Then choose a path $\delta \subset \bar{S} \subset M \times I \times N \times I$ connecting $s_1^1 \in S_1^1$ to $s_2^1 \in S_1^1$ (we assumed \bar{S} to be connected). $\beta \cdot \delta$ can be deformed to $\beta \cdot \delta' \in M \times I \times N \times \{0\}$. So we can conclude:

$$\begin{aligned} \bar{\omega}_1^1 &= \beta_1 \cdot \beta_2 = (\text{pr}_1 \circ H)(\beta) \cdot (\text{pr}_2 \circ H)(\beta^{-1}) \\ &\simeq (\text{pr}_1 \circ H)(\beta \cdot \delta') \cdot (\text{pr}_2 \circ H)(\delta'^{-1} \cdot \beta^{-1}) = \bar{\omega}_2^1, \end{aligned}$$

and thus $[\omega_1^1] = [\omega_2^1]$. Finally let us compare the weightings for s_1^1 and s_1^2 . Again

Figure 3.10. Comparison of $\alpha_w(f_1 \sqcup f_2)$ and $\bar{\alpha}_w(f_2 \sqcup f_1)$

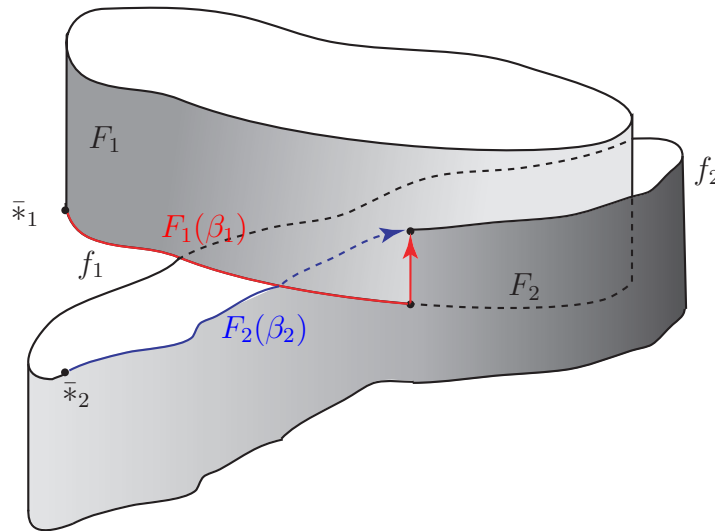

a similar argument as in the proof of lemma 3.15 will be successful. We have to show that $[\omega_1^1]$ is equal to $[(\omega_1^2)^{-1}] \in \lambda(\bar{\sigma}_2, \bar{\sigma}_1)$. But this could easily be realized by a special choice of the path β to compute ω_1^1 . Let δ be a path connecting s_1^1 and s_2^1 . Because $M \times I \times N \times \{0\}$ is a deformation retract of $M \times I \times N \times I$ we can deform $\beta \cdot \delta$ canonically along the projection to the second factor to $\beta' \cdot \delta'$. In figure 3.10, a situation is shown where $F_1 \times F_2$ is already transverse

to $\Delta \subset (Q \times \mathbb{R})^2$. But now we can compute

$$\bar{\omega}_1^1 = (\text{pr}_1 \circ H)(\beta) \cdot (\text{pr}_2 \circ H)(\beta^{-1}) \simeq (\text{pr}_1 \circ H)(\beta' \cdot \delta') \cdot (\text{pr}_2 \circ H)(\delta'^{-1} \cdot \beta'^{-1}).$$

Thus $\bar{\omega}_1^2 := (\text{pr}_2 \circ H)(\beta' \cdot \delta') \cdot (\text{pr}_1 \circ H)(\delta'^{-1} \cdot \beta'^{-1})$ yields $(\bar{\omega}_1^2)^{-1} = \bar{\omega}_1^1$. This completes the proof.

In the second part of this section we will investigate the difference between $\alpha_w(f_1 \sqcup f_2)$ and $\bar{\alpha}_w(f_1 \sqcup f_2)$. To do this let us first define a kind of *intersection pairing of based homotopy classes* in Q .

First we choose $\sigma_1 \in [(M, *_1), (Q, *)]$ and $\sigma_2 \in [(N, *_2), (Q, *)]$. Now we represent σ_1 and σ_2 by maps f_1 and f_2 and deform the product map $f_1 \times f_2$ to a smooth map $H \pitchfork \Delta \subset (Q \times Q)$ (base point preserving; if $n + m < q$ then $*$ should be the only intersection point). Now define for each path component $S_i \subset S = (f_1 \times f_2)^{-1}(\Delta)$, which does not contain $(*_1, *_2)$, an element of $\omega \in \pi_1(Q, *)$ in the same way as in the construction of the weighted linking number α_w . Choose a path β in $M \times N$ connecting $(*_1, *_2)$ to $s_i \in S_i$. Then go along $(\text{pr}_1 \circ H)(\beta)$ to $H(s_i)$. Afterwards go back to $*$ along $(\text{pr}_2 \circ H)(\beta^{-1})$. Summing up over all path components of S we can give the following:

Definition 3.20. For M^m , N^n , and Q^q with prescribed base points, we define:

$$\begin{aligned} I : [(M, *_1), (Q, *)] \times [(N, *_2), (Q, *)] &\rightarrow \Omega_{n+m-q}[\Lambda(\sigma_1, \sigma_2)] \\ (\sigma_1, \sigma_2) &\mapsto \sum [S_i][\omega_i], \end{aligned}$$

where S_i are the path components of S , the coincidence manifold of σ_1 and σ_2 , and $\omega_i \in \pi_1(Q, *)$ as described above. $I(\sigma_1, \sigma_2)$ will be called the *weighted intersection number* of the based homotopy classes σ_1 and σ_2 .

Remark 3.21. That I is well-defined follows in the same manner as in the case of α_w : If f'_1 and f'_2 are another pair representing σ_1 and σ_2 , resp., we can find homotopies of f_1 to f'_1 and f_2 to f'_2 . These homotopies can be used to establish the claimed bordism between the two intersection manifolds in $M \times N$. The homotopies can be used to change the classes of the ω_i too.

Remark 3.22. If we consider Q to be even dimensional with $\dim Q = 2k$ and both M and N are spheres of dimension k , the intersection pairing I is exactly the pairing of Wall in [Wal99], which he used to study the homotopy type of compact manifolds of even dimensions.

Remark 3.23. In a recent paper SCHNEIDERMAN [Sch03] studied weighted (self) linking numbers for knots and two-component links in 3-manifolds in terms of intersections of immersed surfaces in 4-manifolds. He used these linking numbers and self-linking numbers to find complete obstructions for the existence of singular concordances which have all singularities paired by Whitney disks.

We want to use the intersection pairing I to measure the difference between α_w and $\bar{\alpha}_w$:

Theorem 3.24. *Let $f_1 \sqcup f_2 : M \sqcup N \rightarrow Q \times \mathbb{R}$ be a based link map with $f_i(*_i) = \bar{*}_i = (*, (-1)^{i+1}) \in Q \times \mathbb{R}$, and $\sigma_i = [f_i]$ the based homotopy class of each component. Then the following holds:*

$$I(\text{pr}_{1*}(\sigma_1), \text{pr}_{1*}(\sigma_2)) = \alpha_w(f_1 \sqcup f_2) - \bar{\alpha}_w(f_1 \sqcup f_2).$$

PROOF. To prove this theorem take the homotopy $H_1 := F_1$ for f_1 as in the proof of Theorem 3.19. Choose a similar homotopy H_2 to pull down f_1 (as for f_2 in the very same proof). Notice that we choose $m \in \mathbb{R}$ large enough, i.e. such that $Q \times \{0\} \subset H_1(M \times I) \cup H_2(M \times I)$. Now put both homotopies together to produce a map $H : M \times I \rightarrow Q \times \mathbb{R}$:

$$F(x, t) := \begin{cases} H_1(x, 2(t - 1/2)) & \text{for } 1/2 \leq t \leq 1, \\ H_2(x, -2t + 1) & \text{for } 0 \leq t \leq 1/2. \end{cases}$$

It should be clear that the weighted intersection number $\alpha_w(F, f_2)$ is equal to $\alpha_w(f_1 \sqcup f_2) - \bar{\alpha}_w(f_1 \sqcup f_2)$. The minus sign comes from the orientation reversing map $r : I \rightarrow I, t \mapsto -2t + 1$. We have to find an identification of $\alpha_w(F, f_2)$ with $I(\text{pr}_{1*}(\sigma_1), \text{pr}_{1*}(\sigma_2))$. This is based on the fact that $\text{pr}_1 \circ f_1(M) \times \{0\} \subset$

$F(M \times I)$. We choose the canonical homotopy H from f_2 to $\text{pr}_1 \circ f_2$ (with $H(x, t) = H(x, 0)$, $t \in [0, \varepsilon]$ and $H(x, t) = H(x, 1)$ for $t \in [1 - \varepsilon, 1]$). Now bh -approximate $(\text{pr}_1 \circ f_1) \times (\text{pr}_1 \circ f_2)$ smooth and transverse to $\Delta \subset Q^2$. A second bh -approximation can be chosen to make $F \times H$ transverse to $\Delta \subset (Q \times \mathbb{R})^2$. Put both approximations together with a partition of unity argument. An approximation \bar{H} of the resulting map transverse to Δ gives rise to the required formula.

For \bar{H} is equal to a smooth approximation of $(\text{pr}_1 \circ f_1) \times (\text{pr}_1 \circ f_2)$ transverse to Δ , the $n+n-q+1$ -dimensional manifold $\bar{S} := \bar{H}^{-1}(\Delta) \subset M \times I \times N \times I$ produces a bordism \bar{S} between S^0 - the intersection manifold of $\alpha_w(F, f_2)$ - and S^1 which denotes the intersection manifold of $I(\text{pr}_{1*}([f_1]), \text{pr}_{1*}([f_2]))$ (see figure 3.11.). If we now take a path component of \bar{S}_i we denote the components of α_w by

Figure 3.11. Identification of $\alpha_w(F, f_2) = \alpha_w(f_1 \sqcup f_2) - \bar{\alpha}_w(f_1 \sqcup f_2)$ and $I(\text{pr}_{1*}(\sigma_1), \text{pr}_{1*}(\sigma_2))$

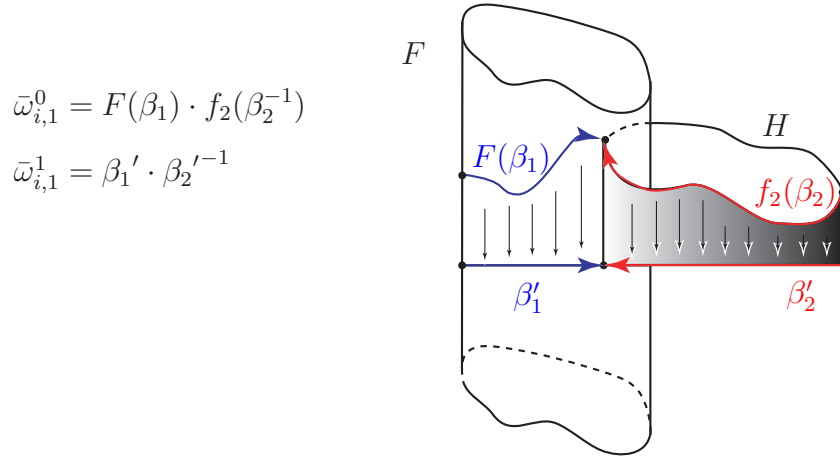

$S_{i,j}^0$ and components of $I(\text{pr}_{1*}(\sigma_1), \text{pr}_{1*}(\sigma_2))$ by $S_{i,j'}^1$. It is not hrd to see that a choice of $\omega_{i,1}^0$ can be deformed using \bar{H} to give a possible path for a weighting of $S_{i,j}^1$. Using H and the canonical deformation $F_1(x, t) = (f_1(x)_1, t f_1(x)_2)$ of f_1 to the image $\text{pr}_1 \circ f_1(M) \times \{0\} \subset Q \times \{0\}$, we get a homotopy of $\omega_{i,1}^0$ to a possible weighting $\omega_{i,j'}^1$ of $S_{i,j'}^1$ for all j' (see figure 3.11.).

4 The classical dimension setting

In this chapter we want to concentrate on the case where M and N are both closed, connected, oriented, one-dimensional manifolds: oriented circles with base points $*_i$, $i = 1, 2$. We define $I := [-2, 2]$. Furthermore let F be a connected, compact, oriented surface. Because $F \times \text{int}(I)$ is diffeomorphic to $F \times \mathbb{R}$ we can apply all results and constructions from chapter 3.

We will study based link maps:

$$f_1 \sqcup f_2 : S^1 \sqcup S^1 \rightarrow F \times I, \quad f_1(S^1) \cap f_2(S^1) = \emptyset,$$

where $f_i(*_i) = \bar{*}_i$, $i = 1, 2$, with $\bar{*}_i := (*, (-1)^{i+1}1)$.

Then define $\sigma_1 := [f_1]$ and $\sigma_2 := [f_2]$ as elements of $\pi_1(F \times I, \bar{*}_1)$ and $\pi_1(F \times I, \bar{*}_2)$, resp. Following the notations of section 3.2 the classes of *based link maps up to base point preserving link homotopy* (with prescribed homotopy classes of f_1 and f_2) will be denoted by $BLM_{(\sigma_1, \sigma_2)}$.

Next we will use the notation $\bar{\sigma}_i := [\text{pr}_i \circ f_i] \in \pi_1(F, *)$. The induced subgroups $(\text{pr}_i \circ f_i)_\#(\pi_1(S^1, *_i))$ are generated by $\bar{\sigma}_i$. Because $\Omega_0^{S^0} \cong \mathbb{Z}$ our invariant - see section 3.2 - takes values in the following free group:

$$\alpha_w : BLM_{(\sigma_1, \sigma_2)} \longrightarrow \mathbb{Z}[\langle \bar{\sigma}_1 \rangle \backslash \pi_1(F, *) / \langle \bar{\sigma}_2 \rangle].$$

This target group will be denoted as in chapter 3 by $\mathbb{Z}[\Lambda_{(\bar{\sigma}_1, \bar{\sigma}_2)}]$. In most cases the cyclic groups $\langle \bar{\sigma}_1 \rangle$ and $\langle \bar{\sigma}_2 \rangle$ are not normal subgroups of $\pi_1(F, *)$ and hence there is no multiplicative structure in $\mathbb{Z}[\Lambda_{(\bar{\sigma}_1, \bar{\sigma}_2)}]$.

The reason for studying base point preserving link homotopy is of technical

nature. In chapter 6 we will see that in the classical dimension setting it is possible to extend the result to the more natural case of base point free link homotopy in some cases.

Before we state the main result of this chapter let us take a look at the 3-manifolds which came up with $F \times I$.

Definition 4.1. A *handle body with n handles* is a 3-manifold M , which contains a collection $\{D_1, \dots, D_n\}$ of pairwise disjoint, properly embedded 2-cells such that the result of cutting M along $\cup D_i$ is a 3-ball.

Lemma 4.2. *Suppose M_i ($i = 1, 2$) are handle bodies with n_i handles. Then M_1 is homeomorphic to M_2 iff $n_1 = n_2$ and both M_1 and M_2 are orientable or nonorientable.*

PROOF. Compare e.g. Hempel [Hem76], Theorem 2.2.

Lemma 4.3. *Let F be a compact, connected, orientable surface of genus g . If $\partial F \neq \emptyset$ and has r components the manifold $F \times I$ is homeomorphic to a 3-ball with $2g + r - 1$ (3-dim.) handles. If $\partial F = \emptyset$ then $F \times I$ is the thickening of a 2-sphere with g (2-dim.) handles.*

PROOF. The proof is an easy consequence of the classification theorem of surfaces. If $\partial F = \emptyset$ the result is clear. If ∂F has $r > 0$ components F is homeomorphic to a 2-sphere with g (2-dim.) handles - denoted by F_g - and r holes. If

Figure 4.1. Surface F with genus g and r holes

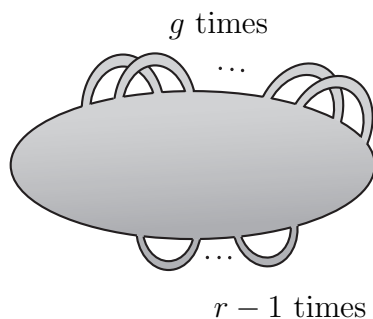

we cut a hole in F_g we obtain a disc with $2g$ handles. Cut another hole is the

same as adding an (untwisted) band, so F is homeomorphic to the surface in figure 4.1.. If we take a thickening of the surface we get a 3-ball with $2g + r - 1$ handles. ■

Now we will state the main result of chapter 3:

Theorem 4.4. *Let F be an oriented, compact, connected surface. Then α_w is a bijection between the set $BLM_{(\sigma_1, \sigma_2)}$ of base point preserving link homotopy classes of based link maps and $\mathbb{Z}[\Lambda_{(\bar{\sigma}_1, \bar{\sigma}_2)}]$.*

The proof will be given in section 4.1. Before we are going to prove the result let us compute some simple examples.

Example 4.5. Let $F = D^2$ the 2-dimensional disc with boundary. Then $\pi_1(F, *) = 1$ and the only pair of (σ_1, σ_2) is $(1, 1)$. So α_w is the well-known linking number in $D \times I$ which is homotopy equivalent to \mathbb{R}^3 .

Example 4.6. If $F = B^2 \setminus \{0\}$, the 2-dimensional annulus, then $F \times I$ is equal to the full torus. So all subgroups are normal in the abelian group $\pi_1(F \times I) = \mathbb{Z}$. If $\bar{\sigma}_1 = m$ and $\bar{\sigma}_2 = n$ then $\mathbb{Z}[\Lambda_{(\bar{\sigma}_1, \bar{\sigma}_2)}] = \mathbb{Z}[\mathbb{Z}]$ if $n = m = 0$ and $\mathbb{Z}[\Lambda_{(\bar{\sigma}_1, \bar{\sigma}_2)}] \cong \mathbb{Z}[m\mathbb{Z} \setminus \mathbb{Z}/n\mathbb{Z}] \cong \mathbb{Z}[\mathbb{Z}_{\gcd(m, n)}]$ otherwise.

Example 4.7. Let $F = T$ be the 2-dimensional torus. $\pi_1(F, *) = \mathbb{Z} \oplus \mathbb{Z}$ is abelian. Therefore all subgroups are normal in $\pi_1(F, *)$. For $\bar{\sigma}_1 = (m, n)$ and $\bar{\sigma}_2 = (m', n')$ we get $\mathbb{Z}[\Lambda_{(\bar{\sigma}_1, \bar{\sigma}_2)}] \cong \mathbb{Z}[(m, n)\mathbb{Z} \setminus \mathbb{Z} \oplus \mathbb{Z}/(m', n')\mathbb{Z}] \cong \mathbb{Z}[\mathbb{Z} \oplus \mathbb{Z}/(m, n)\mathbb{Z} + (m', n')\mathbb{Z}]$ in the case where $(m, n), (m', n') \neq (0, 0)$. If for example $(m', n') = (0, 0)$ and $m, n > 0$, $\gcd(m, n) = 1$ we obtain $\mathbb{Z} \oplus \mathbb{Z}/(m, n)\mathbb{Z}$ as factor group. This group is abelian, finitely generated and torsion-free. So it follows that it is a free abelian group G . The rank of G is smaller or equal to 2, so we obtain $G = \mathbb{Z}$ or $G = \mathbb{Z} \oplus \mathbb{Z}$.

Remark 4.8. The generalization of the examples above to handle bodies with more than one hole shows a much more complicated algebra. Let $B_n := B^2 \setminus \{x_1, x_2, \dots, x_n\}$, $x_i \neq x_j \in \overset{\circ}{B}^2$, $\forall i \neq j$. Then $\pi_1(B_n) = \mathbb{Z} * \mathbb{Z} * \dots * \mathbb{Z}$ (n -times),

the free group with n generators. Now define $g := \bar{\sigma}_1$ and $h := \bar{\sigma}_2$. This yields $\mathbb{Z}[\Lambda_{(g,h)}] = \mathbb{Z}[\langle g \rangle \setminus \mathbb{Z} * \mathbb{Z} * \dots * \mathbb{Z} / \langle h \rangle]$. To decide whether two given double cosets are the same is a kind of the well-known word problem. It seems to be possible to tackle this problem algorithmic (compare e.g. [MKS76]).

Example 4.9. Let $L = l_1 \sqcup l_2$ be the link in picture 4.2. a). We will not distinguish between $l_i : S^1 \rightarrow F \times I$ and the image of this map.

Figure 4.2. Example for a computation of α_w

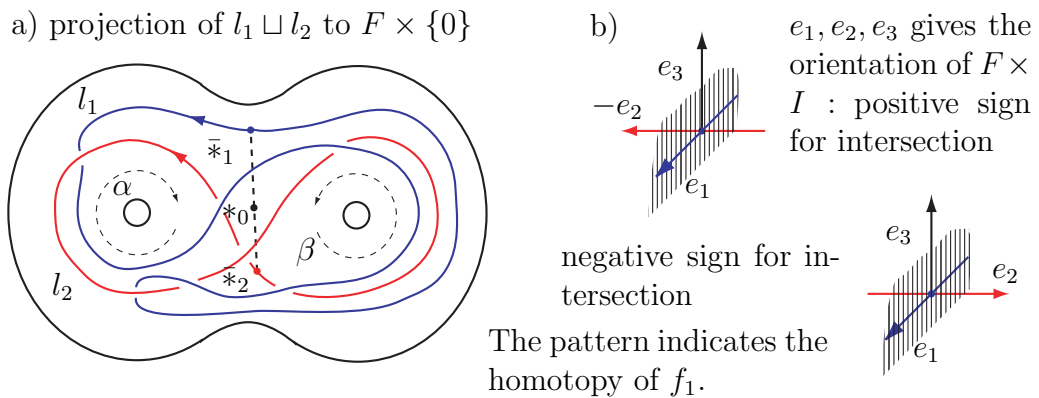

$F \times I$ is oriented such that the restriction to $F \times \{0\}$ has locally the canonical orientation of \mathbb{R}^2 and the third vector is given by the inner normal vector of $F \times \{0\} \subset F \times I$. To compute α_w is as easy as to compute α_w for any classical link in regular projection (all crossings of l_1 and l_2 have to be transversal). Just pull l_1 over all of l_2 . Locally we can describe the homotopy by $l_1 \times Id$. If l_1 was under l_2 we get an intersection point \bar{s}_i . \bar{s}_i corresponds to exactly one point s_i of the intersection manifold $S \subset S^1 \times I \times S^1$ (S is a set of isolated points). Now it is easy to read off the weightings for these intersections. Just follow l_1 from the base point to \bar{s}_i , then go along l_2 to the base point of l_2 . The projection of this curve to F is closed and represents $[\omega_i]$.

It remains to compute the orientation signs of the intersections. To do this we consider the local orientations of $F \times I$ in figure 4.2. b) above: $[e_1, e_3, -e_2]$. The orientation vectors (e_1, e_3) and $-e_2$ are the images of the canonical orientation vectors in the product $T(S^1 \times I)$, TS^1 under $T(l_1 \times Id)$ and Tl_2 , resp., in the

tangent space $T_{\bar{s}_i}(F \times I)$. In the first summand of the isomorphism φ

$$\varphi : T(S^1 \times I \times S^1)|_{s_i} \cong T_{s_i}S_i \oplus ((\text{pr}_1 \circ (l_1 \times Id \times l_2))|_{s_i})^*(T(F \times I))$$

we get $(e_1, 0) = \frac{1}{2}(e_1, -e_1) \pmod{T\Delta}$, $(e_3, 0) = \frac{1}{2}(e_3, -e_3) \pmod{T\Delta}$ and $(0, -e_2) = \frac{1}{2}(e_2, -e_2) \pmod{T\Delta}$ as an orientation basis of $\nu(\Delta, S^1 \times I \times S^1)$. This yields the basis $\frac{1}{2}(e_1, e_3, -e_2)$ in $T_{\bar{s}_i}(F \times I)$. After a rotation we obtain the canonical oriented basis of $T(F \times I)$. So $T_{s_i}S$ will be oriented with a plus sign. In the second picture on the right hand side we get e_1, e_3, e_2 under φ as a basis of $T_{\bar{s}_i}(F \times I)$ and therefore a minus sign in this case.

Now it is easy to see that for the link shown in figure 4.2. a) we compute $\alpha_w(l_1 \sqcup l_2) = [1] - [\beta^{-2}]$.

4.1 Proof of the classification result

In this section we want to show that α_w is able to distinguish all elements in $BLM_{(\sigma_1, \sigma_2)}$. Consider $F \times I$ embedded in \mathbb{R}^3 such that a small neighborhood of $\{*\} \times I$ is equal to $B^2 \times I$ and oriented by the canonical orientation of \mathbb{R}^3 : $[e_1, e_2, e_3]$. If $F \times I$ carries the opposite orientation, we have to make a minor change in the construction below. We will point out it.

Choose representatives $f_1^0 \in \sigma_1$ and $f_2^0 \in \sigma_2$ in $F \times \{1\}$ and $F \times \{-1\}$, resp., in general position. Next we define a special *meridian* m^1 of f_1 . To do this let $p_1 : [0, 1] \rightarrow F \times I$, $t \mapsto (*, -1 + t)$, and p_2 be the path in $F \times I$, which starts in $(*, 0)$ and ends near $(*, 1)$ below the beginning of f_1^0 . Now m^1 is constructed as follows: Start in $(*, -1)$ and go along $p_1 \cdot p_2$, afterwards traverse the boundary of a normal disc of f_1^0 . Finally we have to go back to $(*, -1)$ along $(p_1 \cdot p_2)^{-1}$. The direction on the boundary of the normal disk will be chosen such that the linking number with f_1^0 is $+1$, compare in figure 4.3. (If $F \times I$ has opposite orientation, we have to choose the path which has linking number -1 with f_2 !). This construction leads to a link map $f_1^0 \sqcup \bar{f}_2$, where $\bar{f}_2 := f_2^0 \cdot m^1$. Now α_w can be computed as in example 4.9. Push f_1^0 over f_2^0 . We get a plus sign

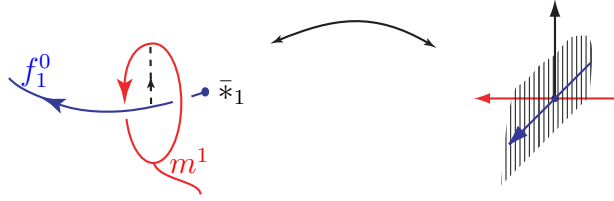
Figure 4.3. Orientation of the meridian m^1 

for the intersection s and the weighting for s is computed by following f_1^0 in orientation direction to s , then down to $(*, -1)$ along the second half of m^1 . In the case of m^1 this path is homotopic to $[0, 1] \ni t \mapsto (*, 1 - 2t) \in F \times I$. But this path projects to c , the constant path $[0, 1] \ni t \rightarrow * \in Q$. Thus we have $\alpha_w(f_1^0 \sqcup (f_2^0 \cdot m^1)) = [1]$.

Following the notation of Milnor in [Mil54] m^γ denotes $\gamma^{-1} \cdot m^1 \cdot \gamma$ for $\gamma \in \pi_1(Q, *)$. A representative for this meridian is given as follows: Go along $p_1 \cdot g^{-1} \cdot p_2$, traverse the boundary of the normal disk and then along $(p_1 \cdot g^{-1} \cdot p_2)^{-1}$ back to $(*, -1)$ (here g is a representative of γ in $Q \times \{0\}$, see figure 4.4. a)). We obtain $\alpha_w(f_1^0 \sqcup (f_2^0 \cdot m^\gamma)) = [\gamma]$.

To construct a link map with $\alpha_w = [-\gamma]$ choose $\bar{f}_2 = f_2^0 \cdot m^{-\gamma} := f_2^0 \cdot (m^\gamma)^{-1}$. Therefore the intersection s will change the sign but the weighting of s in $\pi_1(F, *)$ will be the same. Keep in mind that $m^{-\gamma} = \gamma^{-1} \cdot (m^1)^{-1} \cdot \gamma$ and $m^{\gamma^{-1}} = \gamma \cdot m^1 \cdot \gamma^{-1}$ are represented by paths with same images in $F \times I$ but oriented in opposite direction. It follows $\alpha_w(f_1^0 \sqcup (f_2^0 \cdot m^{\gamma^{-1}})) = [\gamma^{-1}] \neq [-\gamma] = \alpha_w(f_1^0 \sqcup (f_2^0 \cdot m^{-\gamma}))$. Consider the link $f_1^0 \sqcup f_2^0 \cdot m^{\gamma_1} \cdot m^{\gamma_2}$. For each meridian m^{γ_1} and m^{γ_2} we get an intersection s_1 and s_2 , resp. In order to compute the weighting for s_2 , we do not care about the path representing m^{γ_2} because m^{γ_2} is trivial in $\pi_1(F, \bar{*}_2)$. We get $\alpha_w(f_1^0 \sqcup f_2^0 \cdot m^{\gamma_1} \cdot m^{\gamma_2}) = [\gamma_1] + [\gamma_2]$.

Lemma 4.10. *The above construction has a canonical well-defined extension to a map*

$$\varphi : \mathbb{Z}[\pi_1(F, *)] \rightarrow BLM_{(\sigma_1, \sigma_2)}$$

which leads to the following commutative diagram:

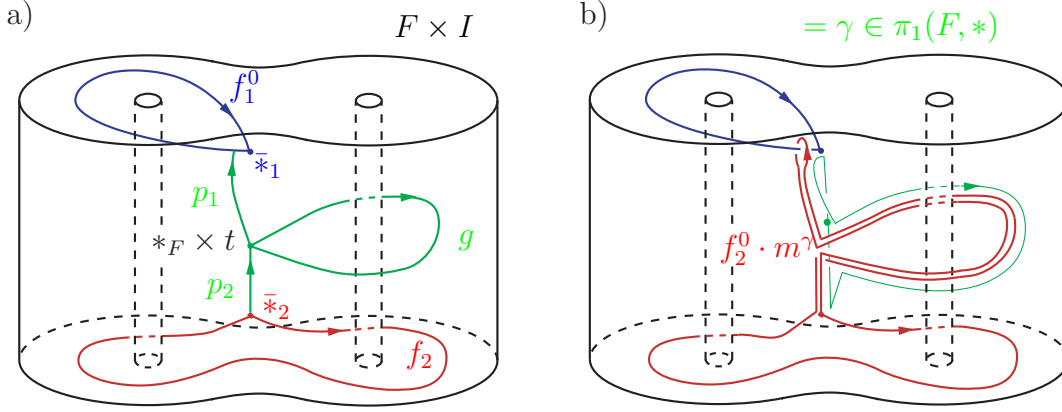
Figure 4.4. Construction of canonical links with prescribed α_w -Invariant

$$\begin{array}{ccc}
 \mathbb{Z}[\pi_1(F, *)] & \xrightarrow{\varphi} & BLM_{(\sigma_1, \sigma_2)} \\
 \text{pr} \downarrow & \swarrow \alpha_w & \\
 \mathbb{Z}[\langle \bar{\sigma}_1 \rangle \setminus \pi_1(F, *) / \langle \bar{\sigma}_2 \rangle] & &
 \end{array}$$

PROOF. First let g and h be two different representatives of $\gamma \in \pi_1(F, *)$. Because $g \sim h \text{ rel } \{0, 1\}$ in $F \times I$, we conclude that $f_2^0 \cdot m^g \sim f_2^0 \cdot m^h \text{ rel } \{0, 1\}$ in the complement of f_1^0 . Thus $f_1^0 \sqcup f_2^0 \cdot m^g$ and $f_1^0 \sqcup f_2^0 \cdot m^h$ are link homotopic.

Next we have $m^\gamma \sim 1$ in $\pi_1(F \times I, *_2)$. Therefore the resulting link map is in $\mathcal{BLM}_{(\sigma_1, \sigma_2)}$ too.

Now the canonical extension φ is given by $\varphi(\gamma_1 + \gamma_2) = [f_1^0 \sqcup f_2^0 \cdot m^{\gamma_1} \cdot m^{\gamma_2}]$. To prove that φ is well-defined we only have to show $[f_1^0 \sqcup f_2^0 \cdot m^{\gamma_2} \cdot m^{\gamma_1}] = [f_1^0 \sqcup f_2^0 \cdot m^{\gamma_1} \cdot m^{\gamma_2}]$ (both will have the same α_w invariant $[\gamma_2] + [\gamma_1] = [\gamma_1] + [\gamma_2]$). Consider the link group $\mathcal{G}(f_1^0) := \pi_1(M) / [\pi_1(M)]$ where $M := (F \times I) \setminus f_1^0(S^1)$ and $[G]$ denotes the commutator subgroup of G . Theorem 3 in [Mil54] states that if l and l' represent conjugate elements in $\mathcal{G}(f_1^0)$ then $f_1^0 \sqcup l \sim f_1^0 \sqcup l'$ up to link homotopy. But we find $f_2^0 \cdot m^{\gamma_2} \cdot m^{\gamma_1} = f_2^0 \cdot m^{\gamma_1} \cdot m^{\gamma_2} \cdot [m^{-\gamma_2}, m^{-\gamma_1}] = f_2^0 \cdot m^{\gamma_1} \cdot m^{\gamma_2} \in \mathcal{G}(f_1^0)$, which completes the proof.

Remark 4.11. The result of theorem 3 in [Mil54] is the reason to introduce the exponential law for meridians: $m^{\gamma_1 + \gamma_2} := m^{\gamma_1} \cdot m^{\gamma_2}$, where $\gamma_1, \gamma_2 \in \pi(F, *)$. A

very similar homotopy showing that $m^{\gamma_1} \cdot m^{\gamma_2} = m^{\gamma_2} \cdot m^{\gamma_1}$ is given in chapter 5, figure 5.2., for meridians in higher dimensions.

Corollary 4.12. *The invariant α_w is surjective.*

Now let us consider the operation of $\langle \bar{\sigma}_1 \rangle$ and $\langle \bar{\sigma}_2 \rangle$ by multiplication on the left and right, respectively. We find that elements in the same orbit will be mapped to the same elements in $BLM_{(\sigma_1, \sigma_2)}$ via φ .

Lemma 4.13. *Let $n, m \in \mathbb{N}_0$ and $\gamma \in \pi_1(F, *)$ and $\bar{\sigma}_i = [\text{pr}_i \circ f_i] \in \pi(F, *)$.*

$$a) \varphi(\bar{\sigma}_1^n \cdot \gamma) = \varphi(\gamma),$$

$$b) \varphi(\gamma \cdot \bar{\sigma}_2^m) = \varphi(\gamma).$$

PROOF. a) Let g be a representative of γ . We will construct a link homotopy:

$$\begin{aligned} f_1^0 \sqcup (f_2^0 \cdot m^\gamma) &= f_1^0 \sqcup (f_2^0 \cdot g^{-1} \cdot m^1 \cdot g) \\ &\sim f_1^0 \sqcup (f_2^0 \cdot (f_2^0 \cdot g)^{-1} \cdot m^1 \cdot (f_2^0 \cdot g)) = f_1^0 \sqcup (f_2^0 \cdot m^{\bar{\sigma}_1 \cdot \gamma}). \end{aligned}$$

This homotopy is given by moving the meridian m^γ around f_1^0 in opposite direction to the orientation of f_1^0 . If we have to pass a crossing of the immersion f_1^0 we can pull down the branch of f_1 on which we move around (see figure 4.5.). We indicate in figure 4.5. that the result extends to all elements of the group $\mathbb{Z}[\Lambda_{(\bar{\sigma}_1, \bar{\sigma}_2)}]$. Intersections of m^γ with the rest of the second component do not matter because we are working in the category of link homotopy where selfintersections are allowed.

To finish the proof of a) we observe that in the case of $\bar{\sigma}_1^{-1}$ we have to move m^γ around f_1^0 in orientation direction.

b) Let again g be a representative of γ . Here we can construct a link homotopy from $f_1^0 \sqcup f_2^0 \cdot m^\gamma$ to $f_1^0 \sqcup f_2^0 \cdot m^{\gamma \cdot \bar{\sigma}_2}$ which is dual to the link homotopy described above. Just pull down the meridian m^γ and extend this to a link homotopy (for more than one meridian this can be done simultaneously because the link homotopy take place in small tubular neighborhood of $m^\gamma \cup D$, where D is a normal disk to f_1^0). This yields a representative $(m^{\gamma^{-1}} \cdot f_1^0) \sqcup f_2^0$. Here $m^{\gamma^{-1}}$ is

Figure 4.5. Link homotopy of $f_1^0 \sqcup (f_2^0 \cdot m^1 \cdot m^\gamma)$ to $f_1^0 \sqcup (f_2^0 \cdot m^{\bar{\sigma}_1} \cdot m^\gamma)$

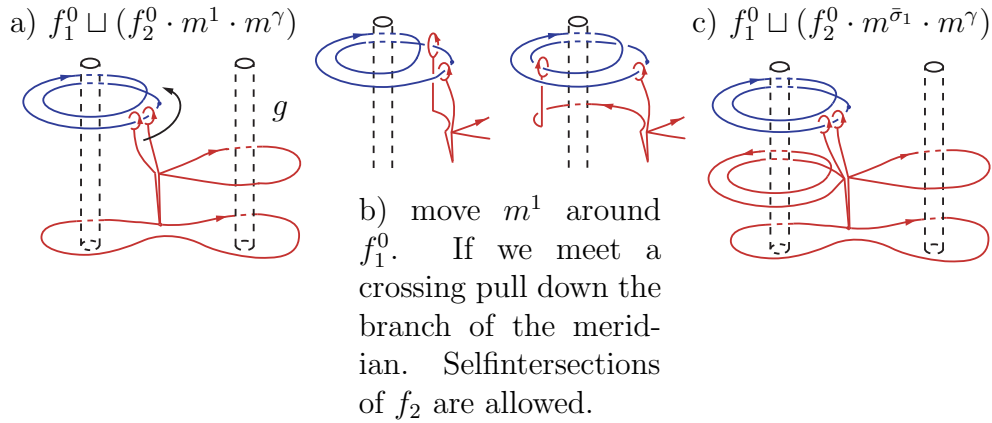

a meridian of f_2^0 (see figure 4.6.). Now we can apply a) to move the meridian $m^{\gamma^{-1}}$ around f_2^0 in orientation direction of f_2^0 . This results in $(m^{\gamma^{-1} \cdot \bar{\sigma}_2^{-1}} \cdot f_1^0) \sqcup f_2^0$. Now pull $m^{\gamma^{-1} \cdot \bar{\sigma}_2^{-1}}$ up and extend this to a link homotopy to get $f_1^0 \sqcup (f_2^0 \cdot m^{\gamma \cdot \bar{\sigma}_2})$. The whole link homotopy is sketched in a sequence of pictures in figure 4.6..

Figure 4.6. Link homotopy of $f_1^0 \sqcup (f_2^0 \cdot m^1 \cdot m^\gamma)$ to $f_1^0 \sqcup (f_2^0 \cdot m^1 \cdot m^{\gamma \cdot \bar{\sigma}_2})$ dual to the homotopy in figure 4.5.

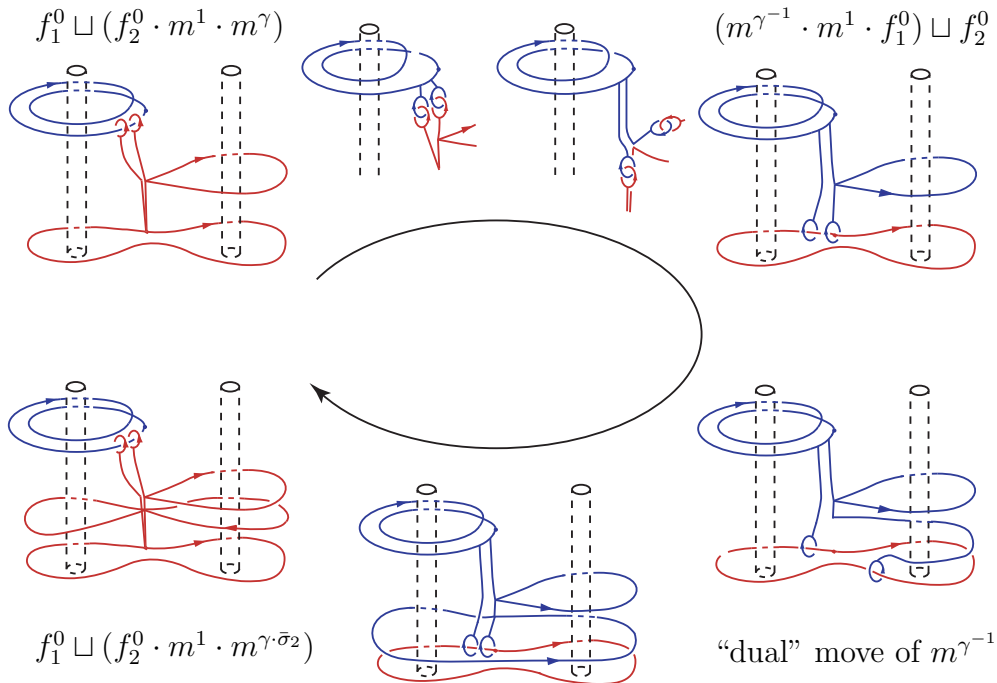

PROOF (PROOF OF THEOREM 4.4.). Lemma 4.10 shows that the surjectivity of α_w holds. It remains to show that α_w is injective. Let $[f_1 \sqcup f_2] = g \in BLM_{(\sigma_1, \sigma_2)}$. First there is a homotopy of f_1 to f_1^0 because both are in the same based homotopy class. This homotopy can be decomposed into a series of isotopies and local crossing changes of f_1 and therefore it can be extended to a link homotopy of $f_1 \sqcup f_2$ to $f_1^0 \sqcup f_2'$, where we have a regular projection P of $f_1^0 \sqcup f_2'$ to $F \times \{0\}$. Denote by \bar{s}_i the intersection points in the regular projection P , where f_2' is “over” f_1^0 . Deform f_2' to $f_2'' \cdot m_1 \cdots \cdots m_n$ with $f_2'' \subset F \times \{0\}$ and m_1, \dots, m_n are meridians of f_1^0 (compare figure 4.7.). The meridians can be moved near the starting point of f_1^0 . Now there is a second homotopy of

Figure 4.7. Deformation of $f = f_1 \sqcup f_2$ into standard form

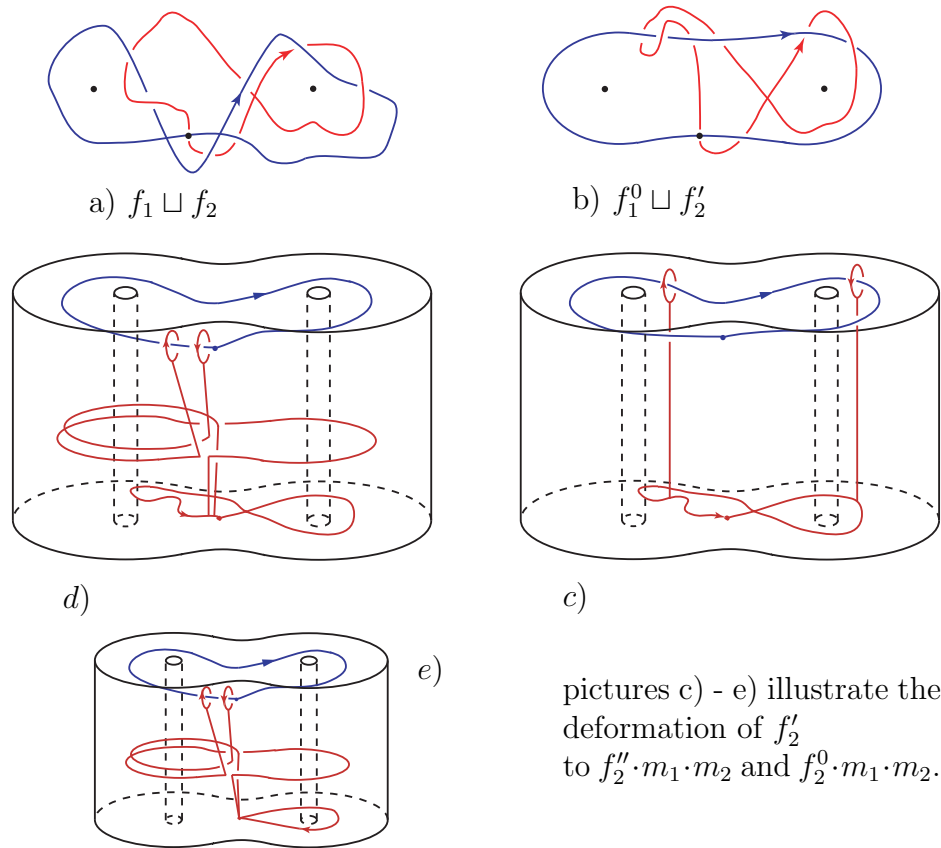

f_2'' to f_2^0 , because $m_i \sim 1$ in $\pi_1(F \times I, \bar{*}_2)$. In view of lemma 4.13 we can define $\bar{\varphi} : \mathbb{Z}[\Lambda_{(\bar{\sigma}_1, \bar{\sigma}_2)}] \rightarrow BLM_{(\sigma_1, \sigma_2)}$ by $\bar{\varphi}(\sum n_g [g]) := \varphi(\sum n_g g)$. But our link homotopy constructed above $f_1 \sqcup f_2 \sim f_1^0 \sqcup (f_2^0 \cdot m_1 \cdots \cdots m_n) =: \bar{f}$ implies the

fact that $\bar{\varphi} \circ \alpha_w = \text{Id}_{BLM(\sigma_1, \sigma_2)}$. It follows that α_w is injective. This completes the proof of theorem 4.4.

Remark 4.14. The result of Theorem 4.4 can be obtained also for framed link maps in classical dimensions. We will see this in the next chapter where we describe a generalization of the construction above.

5 Results in higher dimensions

In this chapter we want to give a generalization of the construction of the last chapter to the higher dimensions in the case of **framed link maps**. First we assume $n + m - q \geq 0$. This is no restriction because in other cases our invariant α_π is zero and $BLM_{(\sigma_1, \sigma_2)}$ consists of exactly one element. To understand it let us consider two link maps $f, g \in \mathcal{BLM}_{M, N}^Q$, $f = f_1 \sqcup f_2$ and $g = g_1 \sqcup g_2$. Next we Choose a homotopy of f_1 to $f'_1 \subset Q \times (]\mathbb{R}_{>g_2}, \infty[\cap]\mathbb{R}_{>f_2}, \infty[)$. Because of the dimension range we can avoid the image of f_2 . In the same way deform g_1 in the complement of g_2 . Then, we clearly have: $(f'_1 \sqcup f_2) \sim (g'_1 \sqcup g_2)$ by a link homotopy. ■

5.1 Construction of link maps in standard form

We start with a based link map

$$f^0 = f_1^0 \sqcup f_2^0 : M^m \sqcup N^n \rightarrow Q^q \times \mathbb{R},$$

of framed manifolds of indicated dimensions with $f_1^0(M) \subset Q \times (1/2, 1]$, $f_1^0(*_1) = (*, 1) =: \bar{*}_1$ and $f_2^0(N) \subset [-1, -1/2)$, $f_2^0(*_2) = (*, -1) =: \bar{*}_2$, where $*$ $\in Q$ denotes the base point of Q and $(*, 0) = \bar{*}$ the base point of $Q \times \mathbb{R}$, resp. This map is surely α_w -trivial, that means $\alpha_w(f^0) = 0$. $f_1^0 \sqcup f_2^0$ can be used to construct a map

$$\begin{aligned} \varphi : \pi_n(S^{q-m}) \times \pi_1(Q, *) &\longrightarrow BLM_{(\sigma_1, \sigma_2)} \\ (g, \tau) &\longmapsto [(g, \tau)(f^0)], \end{aligned}$$

where the operation on f^0 is given in the following way. Take a point $x_0 \in N$ near $*_2$ and a path α_2 connecting x_0 and $*_2$ such that $f_2^0(\alpha_2) \subset B_\epsilon(\bar{*}_2) \subset Q \times \mathbb{R}$ ($Q \times \mathbb{R}$ with Riemannian metric). Consider $f_2^0(x_0) =: (x_1, t)$ and $\gamma : t \mapsto (x_1, t) \in Q \times \mathbb{R}$, $t \in [-1, 1]$. Deform f_1^0 (by a based link homotopy) such that the intersection with γ is exactly the point $(x_1, 1/2)$. Furthermore assume that f_1^0 looks like $(D^m \times D^{q-m}) \times [-\delta, \delta] \hookrightarrow Q \times \mathbb{R}$, where $D^m \times \{0\} \times \{0\}$ is the image of a small ball in M and $\delta > 0$ small, in a neighborhood of $(x_1, 1/2)$. $MS^{q-m} := \partial(D^{q-m} \times [-\delta, \delta])$ is the meridian sphere of $(x_1, 1/2)$, see figure 5.1. on the left. A second path α_1 is chosen on M , connecting $*_1$ to $f_1^{-1}(x_1, 1/2)$, such that $f_1(\alpha_1) \subset B_\epsilon(\bar{*}_1)$.

Now let B be the n -dimensional “balloon” - the wedge of $(S^n, *)$ and $(I, 1)$, with $*$ and 1 being identified. In addition let us consider $N \cup_{x_0} B$, the wedge of N and B , with x_0 and $0 \in I$ being identified. Together with a small open neighborhood U_{x_0} of x_0 we will use an orientation preserving diffeomorphism $h : U_{x_0} \rightarrow B_3^n(0) \subset \mathbb{R}^n$ to construct a map $b : N \rightarrow N \cup_{x_0} B$. Outside of U_{x_0} the map b is defined to be the identity. For $x \in U$ we set:

$$b(x) := \begin{cases} h^{-1}(h(x) \cdot (\|x\| - 2) \cdot 3) \in N & \text{if } 2 \leq \|h(x)\| < 3, \\ \|h(x)\| - 1 \in I & \text{if } 1 \leq \|h(x)\| < 2, \\ h(x) \cdot 1/(1 - \|x\|) \in \mathbb{R}^n \cup \infty = S^n & \text{otherwise, } \infty = * \in S^n. \end{cases}$$

(see figure 5.1. on the right). Furthermore we can assume that the framing on $S^n \subset N$ is trivial up to a sign because it results from a framing over the contractible space U_{x_0} . (A framing on U_{x_0} is a continuous map of U_{x_0} to $GL(n, \mathbb{R})$, which has two path components).

The operation $(g, \tau)(f^0)$ is the composition of b and the map which maps N by f_2^0 , the thread of B to a path from $f_2(x_0)$ to the base point of the meridian sphere MS^{q-m} and S^n to the meridian sphere MS^{q-m} by g . The map of the thread is given as follows: Move along γ from $f_2^0(x_0)$ to $(x_1, 0)$, then follow a loop in $Q \times \{0\}$ representing τ^{-1} and up to $(x_1, 1/2)$, end in the base point of MS^{q-m} (see figure 5.1.). This construction leads to an element of $(g, \tau)(f^0) \in \mathcal{BLM}_{M,N}^Q$.

Figure 5.1. construction of $(g, \tau)(f^0)$

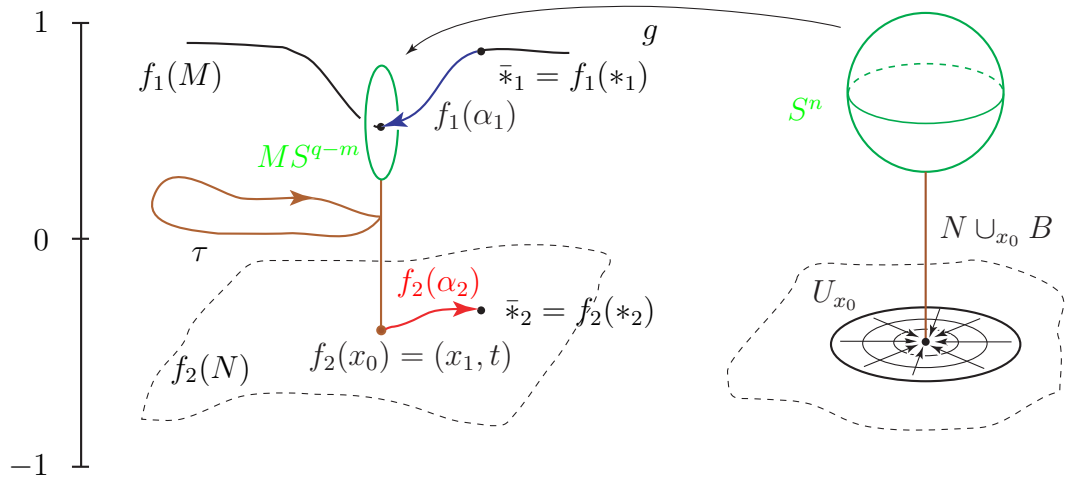

We want to compute $\alpha_\pi((g, \tau)(f^0))$. Use the canonical homotopy along the second component of $Q \times \mathbb{R}$ to pull the image of f_1^0 above $(g, \tau)(f_2^0)$. In the disk neighborhood $(D^m \times D^{q-m}) \times [-\epsilon, \epsilon]$ of $(x_1, 1/2)$ this homotopy is given by:

$$\begin{aligned} H : D^m \times [0, 1] &\rightarrow (D^m \times D^{q-m}) \times [-\epsilon, \epsilon] \\ (x, t) &\mapsto (x, 0, -\epsilon + 2t\epsilon). \end{aligned}$$

So it is easy to see that the only intersection point of H with $(g, \tau)(f_2^0)$ can be the north pole of the meridian sphere MS^{m-q} . We know that α_π is independent from the choice of a transverse approximation of the product map

$$H \times (g, \tau)(f_2^0) : M \times I \times N \rightarrow (Q \times \mathbb{R}) \times (Q \times \mathbb{R})$$

to the diagonal Δ in the target space. We approximate g by a map g' which has the north pole $NP \in S^{q-m}$ as regular value. If $NP \notin g'(S^n)$, then it is clear that $[g] = 0 \in \pi_n(S^n)$; deform $g(x)$ to the base point (south pole) along geodesics (without crossing NP). Hence $(g, \tau)(f^0) \sim f^0$ by a link homotopy, which pulls the balloon along τ .

On the other hand if $g'(S^n) \cap NP \neq \emptyset$ we know that $H \times (g', \tau)(f_2^0)$ is transversal to Δ . This is due to the fact, that H is locally an embedding around

NP , which means that the tangent space of H in NP is $m+1$ -dimensional. The tangent space of the meridian MS in NP is actual the normal space of H in NP . Since g' has NP as regular value, the tangent space $T_x(S^n)$, $x \in g'^{-1}(S^n)$, will be mapped onto $T_{NP}MS^{q-m}$.

The preimage $S := (H \times (g', \tau)(f_2^0))^{-1}(\Delta)$ is equal to $\{x\} \times \{t\} \times S'$ and homeomorphic to $S' \subset S^n \hookrightarrow N \cup_{x_0} B$. Let us now examine the structure of S :

Claim 5.1. The bordism class $[S'] \in \Omega_{n+m-q}^{fr}$, $S' \subset N$ together with $[\tau] \in \Lambda_{(\bar{\sigma}_1, \bar{\sigma}_2)}$ is equal to the value of $\alpha_\pi((g, \tau)f^0)$, at least up to a fixed sign.

PROOF. First note that a framing of $M \times I \times N$ restricted to the preimage $(H \times (g', \tau)(f_2^0))^{-1}(\Delta)$ is trivial up to a sign. That is way both the framing of M over NP and the framing over $S^n \subset N$ could also be assumed to be trivial up to a sign (U_{x_0} is a small contractible neighborhood of x_0 and $S \subset U_{x_0}$). In regard to Remark 3.12 this implicates the following: The induced framing on $(H \times (g', \tau)(f_2^0))^{-1}(\Delta)$ depends only (up to sign) on the vector bundle map

$$TF : \nu(S \hookrightarrow M \times I \times N) \rightarrow \nu(\Delta, (Q \times \mathbb{R}^2)),$$

which transports a framing of Δ to the required framing of S . So the stable framing of S is (\pm) the result of:

$$(Tf_2)^{-1} : \nu(NP \in MS) \rightarrow \nu(S' \subset N).$$

But this is given - again up to sign - by the Pontrjagin-Thom-Construction. ■

Lemma 5.2. If $n \geq 1$ the construction above can be easily extended to the abelian group $\pi_n(S^{q-m})[[\pi_1(Q, *)]]$ of all finite formal linear combinations $\sum(g, \tau)$, where $\tau \in \pi_1(Q, *)$ and $g \in \pi_n(S^{q-m})$. The extension will be denoted by φ again. This yields the commutative diagram:

$$\begin{array}{ccc} \pi_n(S^{q-m})[[\pi_1(Q, *)]] & \xrightarrow{\varphi} & BLM_{(\sigma_1, \sigma_2)} \\ \downarrow \text{proj} & \swarrow \alpha_\pi & \\ \pm E^\infty \circ PT & & \\ \Omega_{n+m-q}^{fr}[[\langle \bar{\sigma}_1 \rangle \setminus \pi_1(Q, *) / \langle \bar{\sigma}_2 \rangle]] & & \end{array} \quad (5.1)$$

PROOF. For each pair (g, τ) choose a point $x \in N$ near $*_2$ and a path α connecting x to $*_2$. Finally choose a path α from x to $(x_1, 0)$. It is clear that for $n \geq 2$ the resulting link map $(g, \tau)(f^0)$ does not depend on the choice of x and α as long as we make our choice in a small neighborhood of $*_2$. We can move around our “balloon” threads to any other position of our choice outside all other wedge points (selfintersections are allowed). Hence we get

$$\varphi((g_1, \tau_1) + (g_2, \tau_2)) = (g_2, \tau_2)((g_1, \tau_1)f^0) = (g_1, \tau_1)((g_2, \tau_2)f^0).$$

In the case of $n = 1$ (and therefore $m = q - 1$: $m \leq q - 1$ and $n + m \geq q$), we have to be more carefully. In this case ($N = S^1$) our balloons are loops that we paste to S^1 . So we have to show that loops pasted in different order yield to the same link map:

$$(f_1^0 \sqcup (f_2^0 \cdot m_1 \cdot m_2)) \sim (f_1^0 \sqcup (f_2^0 \cdot m_2 \cdot m_1 \cdot [m_1^{-1}, m_2^{-1}])) \sim (f_1^0 \sqcup (f_2^0 \cdot m_2 \cdot m_1))$$

up to link homotopy (m_i are meridians of f_1). Here we use a generalization of Milnor’s link homotopy used in Lemma 4.10 for the case $m = n = 1$: He showed that the commutator $[m_1^{-1}, m_2^{-1}]$ is trivial in the link group of f_1 (compare [Mil54]). Consider a small tubular neighborhood D^{q+1} of $m_1 \cup m_2 \cup N_1 \cup N_2$, where N_1 and N_2 are the normal disks of m_1 and m_2 , respectively. The sequence of pictures in figure 5.2. illustrate the desired link homotopy. You can think of the pictures as cuttings of $D^{q+1} \cap (\{0\} \times D^{q-m+2})$, where $\{0\} \in D^{m-1}$. Only a a restriction to one dimension of the image $f_1^0(D^m)$ is lying in this ball. In the construction above m_1 is exactly over m_2 so move m_2 somewhat to the left. Remember that f_1 was locally embedded. Notice that the “finger” moved in this homotopy may have more intersections with f_1 , but this is no problem because selfintersections are allowed.

Because PT is an isomorphism from the stable stem π_{n+m-q}^s to the bordism class of stably framed $n+m-q$ dimensional manifolds we obtain some interesting consequences in conjunction to the suspension theorem of Freudenthal 2.8 and

Figure 5.2. Link homotopy to deform the commutator of two meridians of f_1^0 to a point

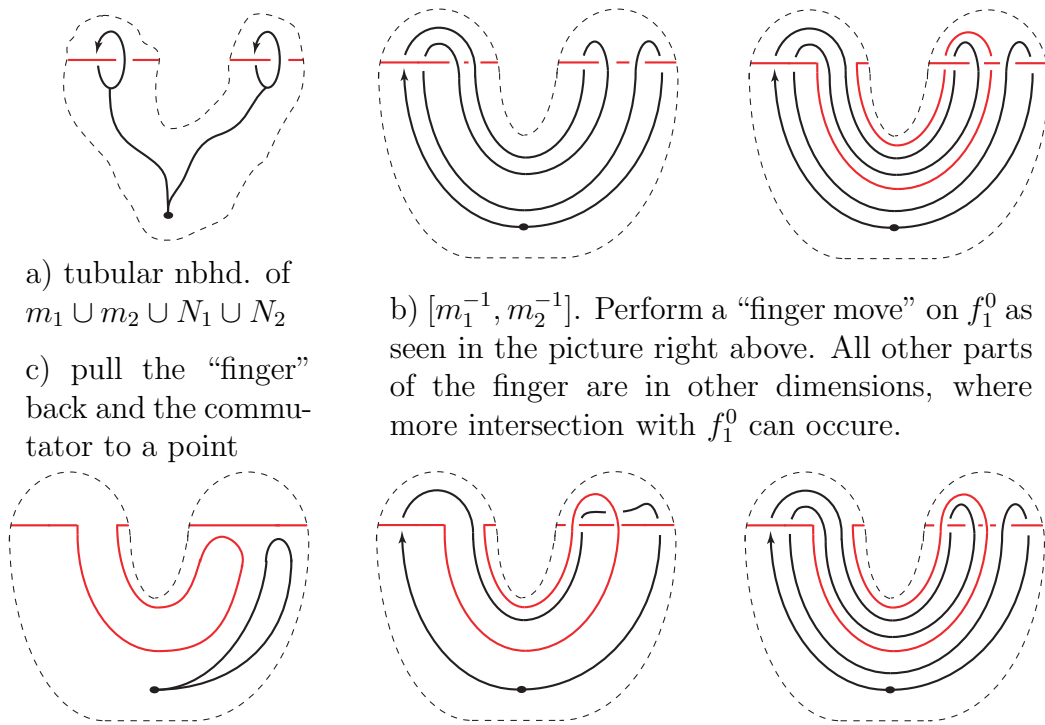

remark 2.9.

Lemma 5.3. *If $1 \leq n \leq 2(q - m) - 1$ and $1 \leq m \leq q - 1$ the invariant α_w is onto. As a consequence α_w distinguishes many different (based) link homotopy classes.*

PROOF. This follows easily from the suspension theorem of Freudenthal 2.8. In the given dimension range the suspension E^∞ is surjective, and because of the commutative diagram (5.1) we conclude that α_w is onto.

5.2 The special case $m + n = q$

Theorem 5.4. *Let $m + n = q$ and $n, m > 0$. Then α_w is a bijection and therefore a full invariant of $BLM_{(\sigma_1, \sigma_2)}$.*

PROOF. In view of lemma 5.3 we have to show that α_w is injective for $n, m \geq 1$.

In a first step we establish a result similar to lemma 4.13 in higher dimensions:

$$\begin{aligned} a) \quad & \varphi(g, \tau) = \varphi(g, \sigma \cdot \tau) \quad \text{for } \sigma \in \bar{\sigma}_1 = (\text{pr}'_1 \circ f_1)_{\#}(\pi_1(M, *_1)), \\ b) \quad & \varphi(g, \tau) = \varphi(g, \tau \cdot \sigma) \quad \text{for } \sigma \in \bar{\sigma}_2 = (\text{pr}'_1 \circ f_2)_{\#}(\pi_1(N, *_2)). \end{aligned} \quad (5.2)$$

a) As well as in the proof of lemma 4.13 we choose a path γ in M whose image under $\text{pr}'_1 \circ f_1^0$ represents σ . We can assume that γ starts and ends in x_0 . Then we approximate f_1^0 by a local embedding near γ . This is possible without changing f_1^0 near $f_1^{0-1}(x_1, 1/2)$. Furthermore we deform f_1^0 in a small tubular neighborhood of $\gamma \in M$ such that $f_1^0(\gamma(I)) \subset Q \times \{1/2\}$ and $f_1^0(M \setminus U(\gamma)) \subset Q \times (1/2, 2]$, where $U(\gamma)$ is a small neighborhood of γ in M .

Now we move the meridian sphere MS^{q-m} along γ^{-1} . Thus the thread will be changed to $\tau \cdot \gamma^{-1}$. Each time where γ^{-1} has a selfintersection pull down the branch where you going along. In this way we come back with MS^{q-m} to $(x_1, 1/2)$ and by a rotation we can assume that the wedge point coincides to the south pole. We choose the meridian sphere so small that it does not meet f_1^0 anywhere. So we changed $f_1^0 \sqcup (g, \tau)f_2^0$ by a link homotopy to $f_1^0 \sqcup (g, \sigma \cdot \tau)f_2^0$. That proves equation a).

In the same way it is possible to construct a link homotopy to deform the balloon along a prescribed path in $f_2^0(N)$ representing σ . Thus b) follows.

In this case we have to choose paths disjoint from the wedge points of all other balloons. There are only difficulties for $n = 1$ or $m = 1$. Consider first the case where $n = 1$. We can use the same “dual move” argument as in lemma 4.13. Use finger moves on $f_1^0(M)$ to perform these “dual moves”.

As in the proof of theorem 4.4 the results above give rise to a map

$$\begin{aligned} \bar{\varphi} : \Lambda_{(\bar{\sigma}_1, \bar{\sigma}_2)} & \rightarrow BLM_{(\sigma_1, \sigma_2)}, \\ \sum n_g [g] & \mapsto \varphi(\sum n_g g). \end{aligned}$$

To complete the proof of theorem 5.4 we deform $f = f_1 \sqcup f_2$ into the standard form. First let us assume that $n \leq m$. Thus we have $2n = q < q + 1$. Therefore we can bh -approximate f_2 by a smooth map f'_2 without selfintersections, [GG80].

Now choose an base point preserving isotopy of f_2' to f_2'' , such that $f_2''(N) \subset Q \times [-1/2, -\infty)$. We extend this isotopy to all of $Q \times \mathbb{R}$ (isotopy extension property, compare [Hir76]).

Because of the \mathbb{R} -factor there is a standard b -homotopy $F : M \times I \rightarrow Q \times \mathbb{R}$ with $F_t(x) = f_1(x)$, $t \in [0, \varepsilon]$, and $F_1(x) = f_1^0(x)$, $t \in [1 - \varepsilon, 1]$. We approximate $F|[\delta, 1 - \delta]$, $\delta < \varepsilon$, smooth, transverse to f_2'' and with normal crossings, i.e. the k -fold product map $F^k : (M \times I)^k \rightarrow (Q \times \mathbb{R})^k$ is transverse to the k -fold diagonal of the target space for all $k \in \mathbb{N}$. Remember that maps with normal crossings are dense in the space of all maps ([GG80], §3, prop 3.2).

This results in a 0-dimensional compact coincidence manifold, i.e. a finite number of points x_1, \dots, x_n . Because we assumed $M \times I$ to be connected we can find paths γ_i which connect x_i to some point $\bar{x} \in M \times \{1\}$ near $*_1 \times \{1\}$. Furthermore we can deform the paths γ_i such that the images are disjoint from all selfintersections of F if $m < q - 1$. This is due to the fact that the double point manifold $S^2 := (F \times F)^{-1}(\Delta) \subset (M \times I)^2$ is of dimension $2(m + 1) - (q + 1) < m$ and so the dimension of the projection to the first factor is smaller than m . If $m = q - 1$ holds the paths can only have intersection points with F . Now

Figure 5.3. finger moves along $F(\gamma_i)$

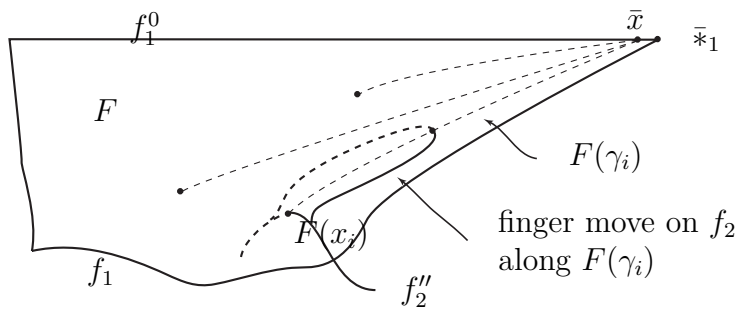

perform finger moves on f_2 along $F(\gamma_i)$ to $F(\bar{x})$ (compare figure 5.3.). Because this is done in a neighborhood of embedded parts of F these finger moves are link homotopies for $f_1 \sqcup f_2''$. If $m = q - 1$ it is possible that the paths meet selfintersections of F . But we can perform crossing changes on f_1 to have a link homotopy in this case too.

Next deform f_1 along F to f_1^0 outside a small neighborhood of $\bar{*}_1$ which

contains $F(\bar{x})$. Afterwards we can deform f_2'' to f_2^0 and pull the end of the fingers afterwards. In a last step collapse the fingers outside the meridians (the finger tips) to paths and move the ends of the paths to points near $\bar{*}_2$ along paths in the image of f_2^0 . That way we have produced the standard form described in the construction. This will complete the proof of theorem 5.4. ■

6 Base point free link homotopy

In this last chapter we want to discuss the more natural relation of base point free link maps up to link homotopy. We will see that in some cases the restriction to the base point preserving link homotopy was only because of technical reasons.

Let us denote the element of $\mathcal{BLM}_{M,N}^Q$ which maps M to $\bar{*}_1$ and N to $\bar{*}_2$ by tr . If we consider $\mathcal{LM}_{M,N}^Q$ as topological space induced by the compact open topology of maps, we know that $\mathcal{BLM}_{M,N}^Q$ is a closed subset of $\mathcal{LM}_{M,N}^Q$. Choose tr as base points for both spaces. This yields the homotopy sequence (of homotopy sets of the pair $(\mathcal{LM}_{M,N}^Q, \mathcal{BLM}_{M,N}^Q)$):

$$\cdots \longrightarrow \pi_1(\mathcal{LM}_{M,N}^Q, \mathcal{BLM}_{M,N}^Q) \xrightarrow{\delta_*} \pi_0(\mathcal{BLM}_{M,N}^Q, tr) \xrightarrow{forg_*} \pi_0(\mathcal{LM}_{M,N}^Q, tr).$$

Here δ_* is the boundary homomorphism and $forg$ is the obvious map forgetting the base points. It is clear that $BLM_{M,N}^Q = \pi_0(\mathcal{BLM}_{M,N}^Q, tr)$ and $LM_{M,N}^Q = \pi_0(\mathcal{LM}_{M,N}^Q, tr)$ holds (note that in our dimension range $q + 1 > 2$). To each link map $f_1 \sqcup f_2 \in \mathcal{LM}_{M,N}^Q$ with $f_i(*_i) = x_i$, it is easy to find a link homotopy to a map $g_1 \sqcup g_2 \in \mathcal{LM}_{M,N}^Q$, such that $g_i(*_i) = \bar{*}_i$, $i = 1, 2$. For instance we can choose a path γ_1 connecting x_1 to $\bar{*}_1$ which does not intersect $f_2(N)$ (again notice that $n \leq q - 1$). So we can do a finger move on f_1 along γ_1 (and therefore in the complement of f_2) such that the resulting map g_1 maps $*_1$ to $\bar{*}_1$. We conclude that $forg_*$ is surjective.

Exactness in the middle means $\ker(forg_*) = \text{im}(\delta_*)$ as subsets of $BLM_{M,N}^Q$. Thus the elements w and z of $BLM_{M,N}^Q$ will be identified under $forg_*$ if there are representatives $f = f_1 \sqcup f_2 \in w$ and $g = g_1 \sqcup g_2 \in z$ such that $f \sim g$ by

a base point free link homotopy. Let us consider what happens if we deform the first component f_1 in the complement of f_2 to f'_1 by a link homotopy F . First observe that $f_{1\#}(\pi_1(M))$ changes to $f'_{1\#}(\pi_1(M))$. The path $\gamma(t) = F(*_1, t)$ leads to an automorphism of $\pi_1(Q, \bar{*}_1)$ which induces an isomorphism between $f_{1\#}(\pi_1(M))$ and $f'_{1\#}(\pi_1(M))$ by $\tau \mapsto [\gamma^{-1}] \cdot \tau \cdot [\gamma]$. That means that the target of α_w changes:

Lemma 6.1. *Let $f = f_1 \sqcup f_2 : M \sqcup N \rightarrow Q \times \mathbb{R}$ be a based link map with $\sigma_i = [f_i]$. Furthermore let $f'_1 : (M, *_1) \rightarrow (Q \times \mathbb{R}, \bar{*}_1)$ be a map in the complement of f_2 and F a base point free link homotopy from $f_1 \sqcup f_2$ to $f'_1 \sqcup f_2$ with $\gamma(t) := F(*_1, t)$, which leaves f_2 fixed. Then*

$$\alpha_w(f_1 \sqcup f_2) = \gamma_*(\alpha_w(f'_1 \sqcup f_2)),$$

where

$$\begin{aligned} \gamma_* : \Omega_{n+m-q}[\Lambda(\bar{\sigma}_1, \bar{\sigma}_2)] &\rightarrow \Omega_{n+m-q}[\Lambda(\bar{\sigma}'_1, \bar{\sigma}_2)] \\ \sum[S_i][\omega_i] &\mapsto \sum[S_i][(\text{pr}'_1 \circ \gamma) \cdot \omega_i]. \end{aligned}$$

PROOF. The proof goes along the lines of the proof that α_w does not change if we deform $f_1 \sqcup f_2$ by a link homotopy of f_1 in the complement of f_2 . We start with a (base point free) homotopy of F_1 of f_1 which satisfies the conditions to compute $\alpha_w(f_1 \sqcup f_2)$. A second homotopy F'_1 is chosen to compute $\alpha_w(f'_1 \sqcup f_2)$. Now the product homotopy $F \cdot F'$ deforms f_1 to f'_1 in the complement of f_2 . Now we have two different homotopies to calculate $\alpha_w(f_1 \sqcup f_2)$. According to lemma 3.15 this yields

$$\alpha_w(F_1, f_2) = \alpha_w(F \cdot F'_1, f_2).$$

In a second step we want to compare $\alpha_w(F \cdot F'_1, f_2)$ with $\alpha_w(F'_1, f_2)$. The coincidence manifolds (with structures) in both computations will be the same because $F(M \times I) \cap f_2(N) = \emptyset$. So it remains to show the claimed translation for our weightings. But this is not hard to see: Consider $M \times I = V_1 \cup V_2 := M \times [0, 1/2] \cup M \times [1/2, 1]$, where V_1 and V_2 correspond to F and F'_1 , resp.

Let S_i be a path component of the coincidence manifold $S = H^{-1}(\Delta)$. Here H denotes a smooth bh -approximation of $F \cdot F'_1$ (Note that the approximation has to be constant near the base point $f_1(*_1)$ and also near $f'_1(*_1)$. This is no crucial restriction.) Let β be a path connecting $(*_1, 0, *_2)$ to $s_i \in S_i$ (compare figure 6.1.). We can deform β in canonical projection direction in $M \times I \times N$

Figure 6.1. Translation of weightings

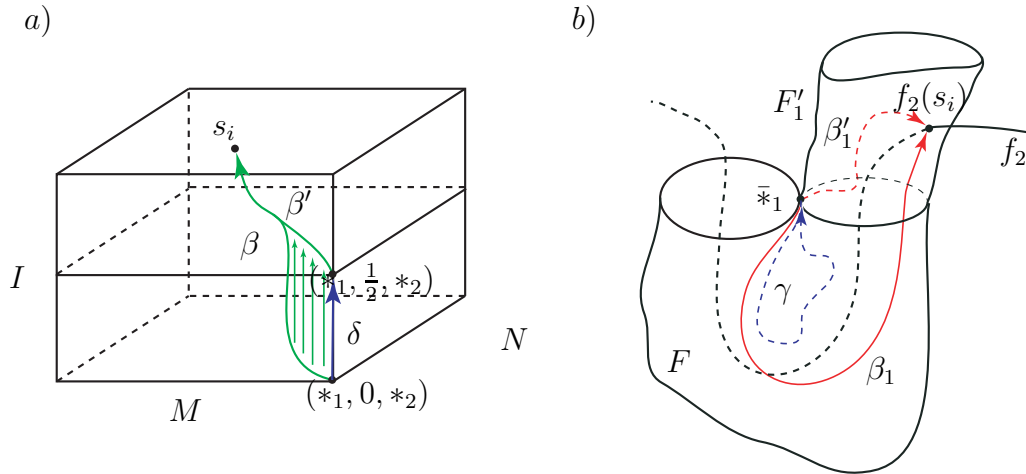

to obtain a composition of two paths: $\delta \cdot \beta'$. The path δ connects $(*_1, 0, *_2)$ to $(*_1, \frac{1}{2}, *_2)$ whereas β' is a path connecting $(*_1, \frac{1}{2}, *_2)$ to s_i . Therefore by our construction one gets:

$$\begin{aligned} \bar{\omega}_i^1 &= \beta_1 \cdot \beta_2 = (\text{pr}_1 \circ H)(\beta) \cdot (\text{pr}_2 \circ H)(\beta^{-1}) \\ &= (\text{pr}_1 \circ H)(\delta \cdot \beta') \cdot (\text{pr}_2 \circ H)(\beta'^{-1} \cdot \delta^{-1}) \\ &\cong \gamma \cdot (\text{pr}_1 \circ H)(\beta') \cdot (\text{pr}_2 \circ H)(\beta'^{-1}) = \gamma \cdot \bar{\omega}_i^2, \end{aligned}$$

where $\bar{\omega}_i^1$ and $\bar{\omega}_i^2$ are used to compute the weightings in $\alpha_w(F \cdot F'_1, f_2)$ and $\alpha_w(F'_1, f_2)$, respectively. This completes the proof of the lemma.

Similar to a deformation of f_1 in the complement of f_2 we can deform f_2 in the complement of f_1 . Using the symmetry relation established in Theorem 3.19, it is easy to show the following

Lemma 6.2. *Let $f = f_1 \sqcup f_2 : M \sqcup N \rightarrow Q \times \mathbb{R}$ be a based link map with $\sigma_i = [f_i]$.*

Furthermore let $f'_2 : (N, *_2) \rightarrow (Q \times \mathbb{R}, \bar{*}_2)$ be a map in the complement of f_1 and F a base point free link homotopy of $f_1 \sqcup f_2$ to $f_1 \sqcup f'_2$ with $\gamma(t) := F(*_2, t)$, which leaves f_1 fixed. Then

$$\alpha_w(f_1 \sqcup f_2) = \gamma^*(\alpha_w(f_1 \sqcup f'_2)),$$

where $\gamma^*(\sum[S_i][\omega_i]) := \sum[S_i][\omega_i \cdot (\text{pr}'_1 \circ \gamma)]$ and $\text{pr}'_1 : Q \times \mathbb{R} \rightarrow Q$ is the projection to the first factor.

Recall that any (base point free) link homotopy F of $f_1 \sqcup f_2$ splits into homotopies F_i of one component in the complement of the other one. This can be done such that F_i is a base point free homotopy of based maps (push the base point of M and N to $\bar{*}_1$ and $\bar{*}_2$, resp., after each deformation F_i).

Similar to the base point preserving case we have the splitting

$$LM_{M,N}^Q = \bigcup LM_{(\sigma_1^{fr}, \sigma_2^{fr})},$$

where σ_1^{fr} and σ_2^{fr} are the free homotopy classes of f_1 and f_2 , respectively. Putting these facts together we can establish the following functorial description:

Proposition 6.3. *Choose free homotopy classes $\sigma_1^{fr} \in [M, Q]$ and $\sigma_2^{fr} \in [N, Q]$. Consider the category \mathcal{C} with objects $\bigcup \mathcal{BLM}_{(\sigma_1, \sigma_2)}$, where $\text{forg}_*(\sigma_i) = \sigma_i^{fr}$, i.e. by forgetting the base point σ_i is mapped to σ_i^{fr} . The morphisms in \mathcal{C} are base point free link homotopies. Then α_w induces a functor between \mathcal{C} and the category \mathcal{AB} . The objects of \mathcal{AB} are abelian groups and the morphisms are isomorphisms between them. In particular we have the following commutative diagram:*

$$\begin{array}{ccc} f = f_1 \sqcup f_2 & \xrightarrow{\alpha_w} & \Omega_{n+m-q} \llbracket \Lambda_{(\bar{\sigma}_1, \bar{\sigma}_2)} \rrbracket \\ H \downarrow & & \downarrow \alpha_w(H) \\ g = g_1 \sqcup g_2 & \xrightarrow{\alpha_w} & \Omega_{n+m-q} \llbracket \Lambda_{(\bar{\sigma}'_1, \bar{\sigma}'_2)} \rrbracket, \end{array}$$

where $f \in \mathcal{BLM}_{(\sigma_1, \sigma_2)}$ and $g \in \mathcal{BLM}_{(\sigma'_1, \sigma'_2)}$ are based link maps and H is a base point free link homotopy of f to g and $\alpha_w(H)$ is the isomorphism induced by the trace of $*_1$ and $*_2$ under H . ■

Given a link map f we denote by f^b a fixed based representative of the (free) link homotopy class of f . All based representatives (up to based link homotopy) can be constructed in the following way: Choose $\gamma_1 \in \pi_1(Q, \bar{*}_1)$ and $\gamma_2 \in \pi_1(Q, \bar{*}_2)$. Then define $f_{(\gamma_1, \gamma_2)}^b$ as the result of the free link homotopy which pushes $*_1$ along a loop representing γ_1 and $*_2$ along a loop representing γ_2 . Because we assumed that $m, n \leq q - 1$, both homotopies can be chosen such that there is no intersection with the other component.

Let us compare two given (base point free) link maps f and g . In view of Proposition 6.3 we have the following

Proposition 6.4. *If $\alpha_w(f^b) \neq \alpha_w(g_{(\gamma_1, \gamma_2)}^b)$ for all elements $(\gamma_1, \gamma_2) \in \pi_1(Q, \bar{*}_1) \times \pi_1(Q, \bar{*}_2)$. Then f and g are not link homotopic.*

PROOF. Choose basings f^b and g^b . These basings together with the link homotopy of f to g yield a base point free link homotopy of f^b to g^b . Now by Proposition 6.3 we know that there is an element $(\gamma_1, \gamma_2) \in \pi_1(Q, *) \times \pi_1(Q, *)$, such that $\alpha_w(f^b) = \alpha_w(g_{(\gamma_1, \gamma_2)}^b)$.

Consider now the case where $\pi_1(Q, *)$ is an abelian group, or more generally where $\bar{\sigma}_1$ and $\bar{\sigma}_2$ are subgroups of the centralizer of $\pi_1(Q, *)$. Then the target of α_w does not change, i.e. $f_{1\#}(\pi_1(M, *_{1})) = f'_{1\#}(\pi_1(M, *_{1}))$ if $f_1 \sim f'_1$ in the complement of f_2 . So our invariant α_w lifts to an invariant $\tilde{\alpha}_w$ of base point free link maps:

Theorem 6.5. *Let $f = f_1 \sqcup f_2 : M^m \times N^n \rightarrow Q^q \times \mathbb{R}$ be a link map of manifolds with given structures ($1 \leq m, n \leq q - 1$). Furthermore let $\bar{\sigma}_1$ and $\bar{\sigma}_2$ be subgroups of the center of $\pi_1(Q, *)$. Pick a base point preserving representative f^b of its link homotopy class. We define $\sum[S_i][\omega_i] \sim \sum[S_i][\omega'_i]$ iff there are $\gamma_1, \gamma_2 \in \pi_1(Q, *)$, such that $[\omega_i] = [\gamma_1 \cdot \omega'_i \cdot \gamma_2]$ for all i . Then the orbit*

$$[\alpha_w(f_1^b \sqcup f_2^b)] \in \Omega_{n+m-q}[\Lambda_{(\bar{\sigma}_1, \bar{\sigma}_2)}] / \sim$$

with respect to the relation described above depends only on the base point free link homotopy class of f and is called the $\tilde{\alpha}_w$ -invariant of f . ■

In view of the remark at the beginning of this chapter we can state the following classification theorem:

Theorem 6.6. *Let $m+n = q \geq 2$ and M, N and Q stably framed manifolds of dimension $m, n \geq 1$ and q , resp. Furthermore assume that $\pi_1(Q, *)$ is abelian or $\pi_1(M, *_1) = 1 = \pi_1(N, *_2)$. Then the invariant $\tilde{\alpha}_w$ is a bijection between $LM_{M,N}^Q$ and $\Omega_0^{fr}[\Lambda_{(\bar{\sigma}_1, \bar{\sigma}_2)}] / \sim$. The same is true in the case of two oriented circles in $F \times I$, where F is an oriented surface with abelian fundamental group.*

■

(compare Theorem 4.4 and 5.4).

Theorem 6.6 extends in some sense results of Dahlmeier [Dah94], Satz I, and U. Koschorke [Kos03a].

Bibliography

- [Ada93] M. Adachi, *Embeddings and immersions, Translated from the Japanese by Kiki Hudson*, Translations of Mathematical Monographs. 124. Providence, RI: American Mathematical Society (AMS), 1993.
- [Dah94] U. Dahlmeier, *Verkettungshomotopien in Mannigfaltigkeiten*, Ph.D. thesis, Universität Siegen, 1994.
- [DK01] J. F. Davis and P. Kirk, *Lecture notes in algebraic topology*, Graduate Studies in Mathematics, American Math. Society, 2001.
- [Fen86] D. Fenn, R. & Rolfsen, *Spheres may link homotopically in 4-space*, J. Lond. Math. Soc., II. Ser. **34** (1986), 177–184 (English).
- [GG80] M. Golubitsky and V. Guillemin, *Stable mappings and their singularities, 2nd corr. printing*, Graduate Texts in Mathematics, 14. New York - Heidelberg - Berlin: Springer-Verlag. XI, 209 p. DM 34.00; \$ 20.10 , 1980 (English).
- [Hem76] J. Hempel, *3-manifolds*, Annals of Mathematics Studies, 86. Princeton, New Jersey: Princeton University Press and University of Tokyo Press. XII, 195 p., 1976 (English).
- [HH63] A. Haefliger and M. Hirsch, *On the existence and classification of differentiable embeddings*, Topology **2** (1963), 129–135.

- [Hir76] M. Hirsch, *Differential topology*, Graduate texts in mathematics, no. 20, Springer-Verlag, 1976.
- [HK98] N. Habegger and U. Kaiser, *Link homotopy in the 2-metastable range*, *Topology* **37** (1998), no. 1, 75–94.
- [Kir88] P. A. Kirk, *Link maps in the four sphere*, *Differential topology, Proc. 2nd Topology Symp., Siegen/FRG 1987*, Lect. Notes Math. 1350, 31–43, Springer-Verlag, 1988.
- [Kir90] ———, *Link homotopy with one codimension two component*, *Trans. Am. Math. Soc.* **319** (1990), no. 2, 663–688.
- [Kos88] U. Koschorke, *Link maps and the geometry of their invariants*, *Manuscr. Math.* **61** (1988), no. 4, 383–415.
- [Kos90] ———, *On link maps and their homotopy classification*, *Math. Ann.* **286** (1990), no. 4, 753–782.
- [Kos92] ———, *Geometric link homotopy invariants*, *Knots 90, Proc. Int. Conf. Knot Theory Rel. Topics, Osaka/Japan 1990*, 117–124, de Gruyter Verlag, 1992.
- [Kos03a] ———, *Link maps in arbitrary manifolds and their homotopy invariants*, *J. Knot Theory Ramifications* **12** (2003), no. 1, 79–104.
- [Kos03b] ———, *Nielsen coincidence theory in arbitrary codimensions*, preprint (2003), 23.
- [Mil54] John W. Milnor, *Link groups*, *Ann. Math. (2)* **59** (1954), 177–195.
- [Mil65] J. W. Milnor, *Topology from the differential viewpoint*, University Press of Virginia, Charlottesville, 1965.
- [MKS76] Wilhelm Magnus, Abraham Karrass, and Donald Solitar, *Combinatorial group theory, Presentations of groups in terms of generators and*

- relations, 2nd rev. ed.*, Dover Books on Advanced Mathematics. New York: Dover Publications, Inc. XII, 1976.
- [MR85] W.S. Massey and D. Rolfsen, *Homotopy classification of higher dimensional links*, Indiana Univ. Math. J. **34** (1985), 375–391.
- [MS74] J. W. Milnor and J. D. Stasheff, *Characteristic classes*, Annals of Mathematics Studies. No.76. Princeton, N.J.: Princeton University Press and University of Tokyo Press. VII, 1974 (English).
- [Nez91] V.M. Nezhinskij, *Groups of classes of pseudohomotopic singular links, I*, 1991, pp. 296–302.
- [Pil97] A. Pilz, *Verschlingungshomotopie von 2-Sphären im 4-dimensionalen Raum*, 1997, diploma-thesis.
- [Pon38] L.S. Pontrjagin, *A classification of continuous transformations of a complex into a sphere, I*, C. R. (Dokl.) Acad. Sci. URSS, n. Ser. **19** (1938), 147–149 (English).
- [Pon59] ———, *Smooth manifolds and their applications in homotopy theory*, Am. Math. Soc., Transl., II. Ser. **11** (1959), 1–114 (Russian, English).
- [Sch03] R. Schneiderman, *Algebraic linking numbers of knots in 3-manifolds*, Algebr. Geom. Topol. **3** (2003), 921–968 (English).
- [Sco68] G.P. Scott, *Homotopy links*, Abh. Math. Semin. Univ. Hamb. **32** (1968), 186–190.
- [Sto58] R. E. Stong, *Notes on cobordism theory*, Princeton Math. Notes, Princeton Univ. Press, 1958.
- [SZ94] R. Stöcker and H. Zieschang, *Algebraische topologie*, 2. Auflage, Teubner Verlag, 1994.
- [Tho54] R. Thom, *Quelques propriétés globales des variétés différentiables*, Comment. Math. Helv. **28** (1954), 17–86 (French).

- [Wal99] C.T.C. Wall, *Surgery on compact manifolds, 2nd ed.*, Mathematical Surveys and Monographs. 69. Providence, RI: American Mathematical Society (AMS), 1999 (English).
- [Whi44] H. Whitney, *The self-intersections of a smooth n -manifold in $2n$ -space*, Ann. of Math. (1944), 220–246 (English).
- [Whi78] G. W. Whitehead, *Elements of homotopy theory*, Graduate Texts in Mathematics. 61. Berlin-Heidelberg-New York: Springer-Verlag. XXI, 1978.